

BASE MODEL: D1036-D-FBO-NFPA

Job Name: _____ Date: _____ Mark: _____

Reference: _____ Unit Location: _____ Prepared By: _____

Engineer: _____ Contractor: _____ Approval: _____

Expected Job Date: _____ Notes: _____

MODEL FAN OPTIONS

Integral Fans: **F** - Recirculating **R** - Rear Discharging

Top Discharging External Fans: **FBO** - Fan by Others Module **IF** - Inline Fan **RF** - Roof Mounted Fan **WF** - Wall Mounted Fan

SELECT OPTIONAL ACCESSORIES

- | | |
|--|---|
| <input type="checkbox"/> ADA: ADA Fan/Light Control | <input type="checkbox"/> D1036-TC-D: Top Cover |
| <input checked="" type="checkbox"/> CLBX: ClockBox | <input type="checkbox"/> MACM: Make-Up Air Control Module |
| <input type="checkbox"/> CC: Custom Color - (Stainless Standard) Specify Color: _____ | <input type="checkbox"/> STROBE: Horn and Light Strobe Alarm |
| <input type="checkbox"/> TANK-TEST: Test Tank | <input type="checkbox"/> CFCS: Common Fan Control |
| <input checked="" type="checkbox"/> MPK: Manual Pull Station- Part of Option | <input type="checkbox"/> PD4X: Power Distribution Box |

RANGE FUEL SOURCE DISCONNECT OPTIONS (CHECK APPROPRIATE RECEPTACLE)

- | | |
|--|---|
| <input type="checkbox"/> G: 3/4" NPT Natural Gas (DED Needed if Electric Components Need to be Controlled on a Gas Range) | <input checked="" type="checkbox"/> DED: Dual Element (includes 3/4" NPT Natural Gas and Electric) -
<input type="radio"/> 14-50R, 220VAC <input type="radio"/> 5-20R, 120VAC |
| <input type="checkbox"/> E: Electric -
<input type="radio"/> 14-50R, 220VAC <input type="radio"/> 6-20R, 220VAC
<input type="radio"/> 10-50R, 120VAC <input type="radio"/> 5-20R, 120VAC
<input type="radio"/> 5-15R, 120VAC | <input type="checkbox"/> DRD: Dual Receptacle -
<input type="radio"/> 6-20R, 220VAC <input type="radio"/> 5-15R, 120VAC <input type="radio"/> 5-20R, 120VAC |

ELECTRIC NEMA (RECEPTACLE) OPTIONS

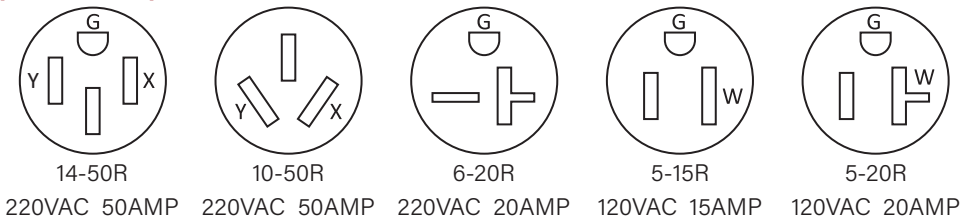

Contact factory for any special circumstances

REQUIREMENTS

Hood shall:

- Be D1000 Series by DENLAR Fire Protection
- Be wall mounted so that the bottom of the mounting bracket sits 30" to 36" above the range
- Be of stainless-steel construction (#18 & #20 GA, polished 304) with no sharp edges and brushed finish
- Have factory installed fire suppression system
- Have 280° F degree fusible link (36") which will activate the mechanical fire suppression system
- Have wet chemical extinguishing agent: Low PH Amerex 660 (pressurized potassium citrate / potassium acetate mix)
- Fan by others must have centrifugal fan with air delivery
- Be ETL listed, tested to UL300A standard
- Fan by others motor shall be permanently lubricated and meet UL507 standard, CFM should achieve at least 500CFM for compliance
- Include a power disconnect for gas and/or electric appliances, deactivated at suppression system discharge
- Automatically disconnect range element once a certain pre-set temperature is reached or under particular predefined events or conditions
- Unit shall have multiple alarm contacts pre-installed (local, remote and trouble alarms) and an audible buzzer
- Lighting shall be LED bulb

BASE MODEL: D1036-D-FBO-NFPA



GENERAL FEATURES

- ETL/CSA listed
- 304 Brushed Stainless Steel
- Fail-Safe mechanical actuation
- Two step pre-suppression
- Plenum nozzle
- Main power switch and reset switch
- Service switch
- Pressure switch
- Pressure gauge
- Temperature switches
- Hard wired fuel source disconnect
- Dry alarm contacts
- On board diagnostics
- Status LED
- Trouble signal
- Service key
- Audible buzzer (90db)
- LED bulb
- Grease baffle with drip tray

UNIT DIMENSIONS

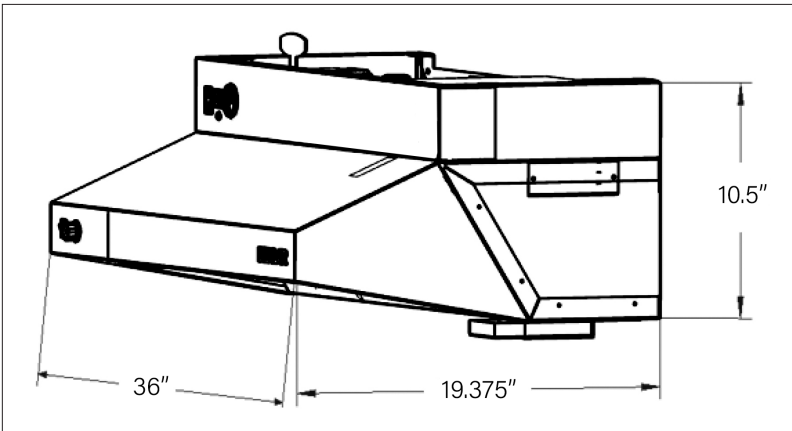

REQUIRED FOR ALL MODELS



The main unit requires clearance to tilt to a 45° degree angle for maintenance purposes

SPECIFICATIONS

Compliance	UL300A, NSF, UL507, and NFPA101 compliant
Weight	56.8 lbs
Min / Max Install Height Above Top of Residential Range / Cook Top	30" - 36"
Voltage	120 AC
Phase	1
Hz	60 Hz
Amps	2 Amps
Circuit Breaker Size	15-20 Amps
Operating Current	N/A
Fan Operating Current	N/A
Output Operating Current	0.25 to 0.5 Amps
Input Wiring	Power Cord
Output Wiring	14/2 MC Wire
Fan Type	Fan By Others / 3rd Party Supplies Fan, (Fan is External)
MOCP	15 Amps
Duct Type	See Local Codes
Fire Control	Programmable Logic Controller
Tank Type	Stainless Steel
Tank Pressure	102+ -8% Psi
Tank Volume	1300 mL
Suppression Agent	Low pH Wet Chemical Amerex 660
No. of Nozzles / Spray	4 / 60 Degree Conical

NOZZLE PLACEMENT

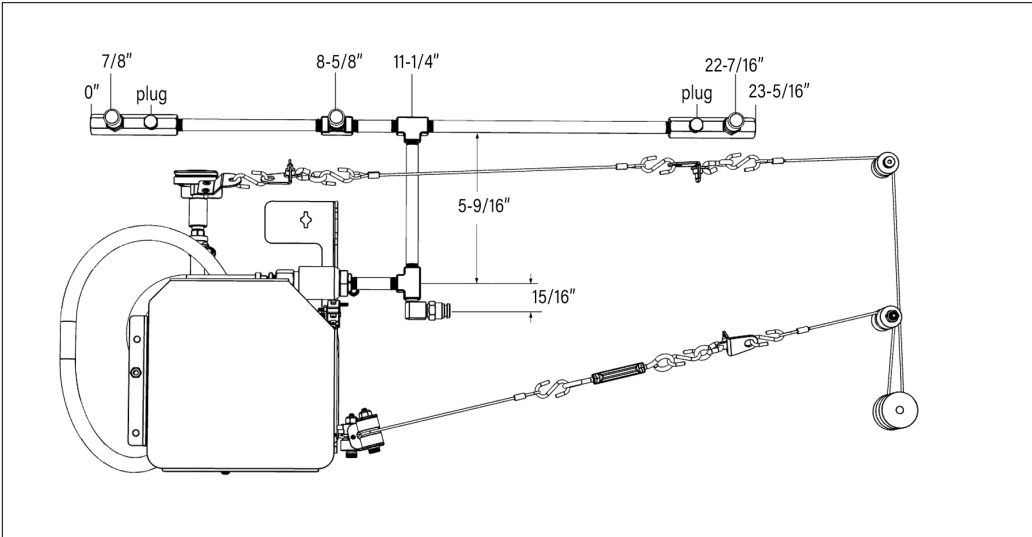

TOP DUCTED EXHAUST

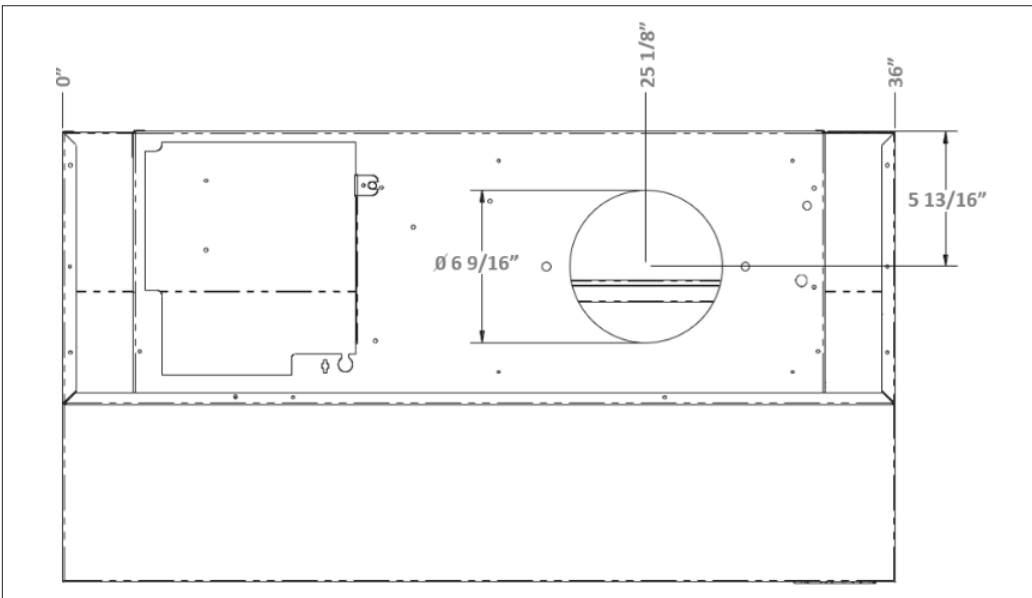

DUAL ELEMENT STOVE POWER SOURCE DISCONNECT: -DED (D1000)

ELECTRIC RECEPTACLE DIMENSIONS

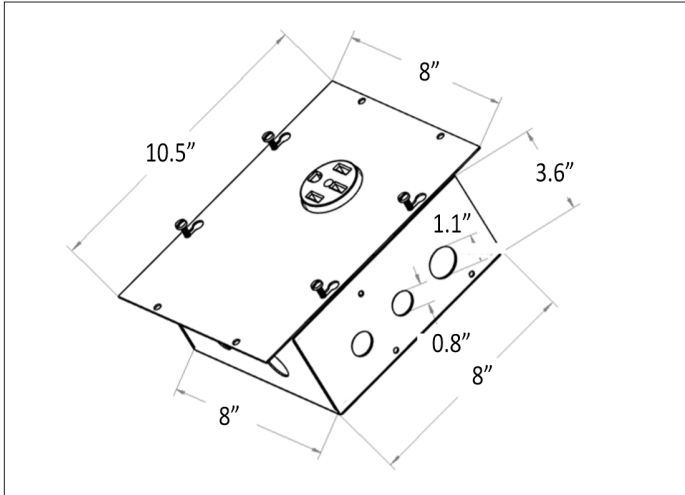

ELECTRIC RECEPTACLE SPECIFICATIONS

Models	-DED-220 14-50	-DED 120 5-20
Weight	5.4 lbs.	
NEMA	14-50 R	5-20 R
Output Volts	220 AC	120 AC
Output Current	50 Amps	20 Amps
Coil Voltage	120	
Phase	1	
Frequency	60 Hz	
Fuse	0.5 Amps	
Fuse Type	5 X 20mm cartridge	
Operating Current	0.25 Amps	
Material	Galvanized	
Mounting Type	Surface or flush mount	
Mounting Height	See local codes	

GAS VALVE DIMENSIONS

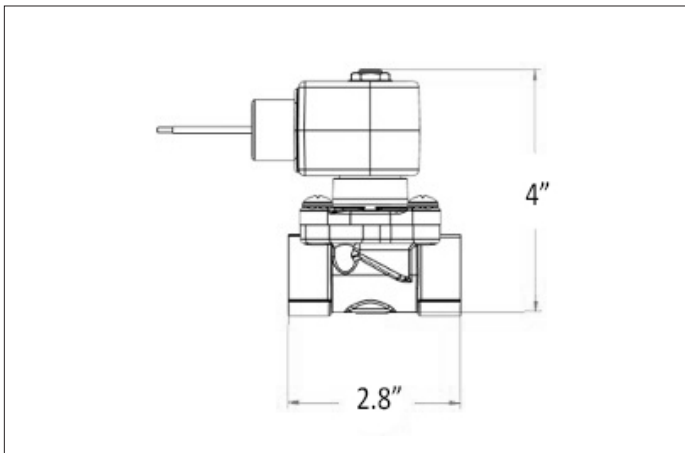

GAS VALVE SPECIFICATIONS

Coil Voltage	120 AC
Phase	1
Frequency	60 Hz
Fuse	0.5 Amps
Operating Current	0.25 Amps
Valve Type	2-Way
Function	Normally closed
Actuation Type Coil Type	Direct lift
Coil Type	½" NPT conduit, 18' leads, class F, NEMA 4X
Body Material	Brass
Seal Material	NBR
Orifice Size	7/16"
Port Size	3/4"
Number Of Ports	2
Port Type	NPT
Media	General purpose for air, liquids, and gases
Min. Pressure Differential	0 PSI
Max. Pressure Differential	100 PSI (AC)
Min. Fluid Temperature	0° F
Max. Fluid Temperature	185° F
Flow Coefficient	5 CV

DUAL ELEMENT POWER SOURCE DISCONNECT: -DED

SCHEMATIC

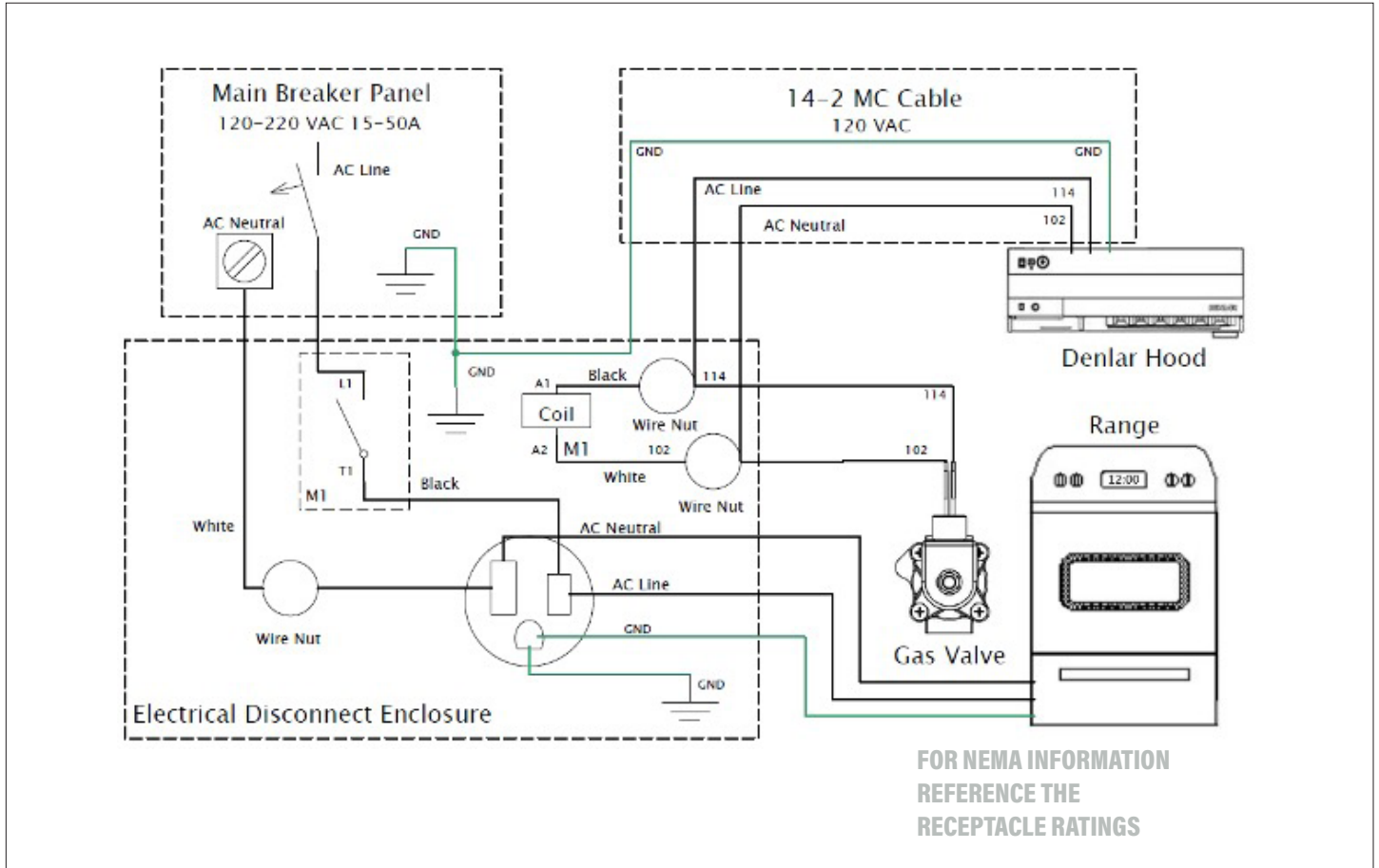

FAN: -FBO-NFPA (PRO) 36"

SCHEMATIC

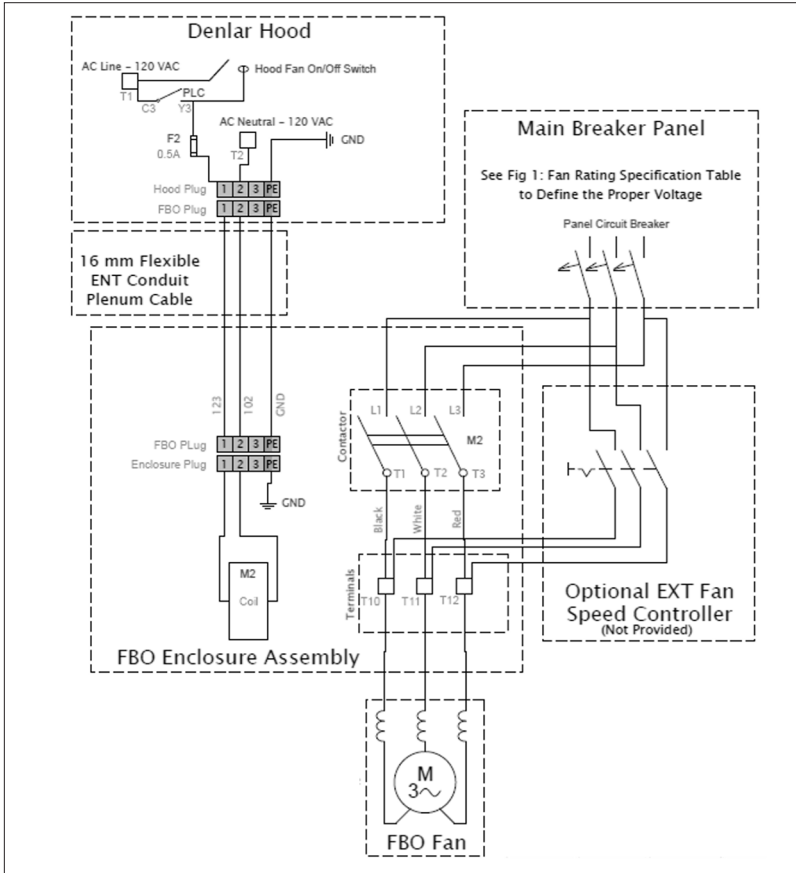

SPECIFICATIONS

Style	N/A
Type	3rd party supplied
Weight	6.4 lbs.
Operating Current	0.25 Amps
Voltage	120 AC
Phase	1
Frequency	60 Hz
CFM + -2.5% (Low-High)	N/A (500 Required for Compliance)
Pressure (In Water)	N/A
dBa (Low-High)	N/A
Hood Outlet (Low-High)	7 in (Dia)
Duct	N/A
Fan Inlet	N/A
Fan Outlet	N/A
Control	ON/OFF
Speeds	Single Speed
Fuse	0.5 Amps
Fuse Type	5 mm x 20 mm
Mounting Configuration	Surface Mount or Flush Mount

Fan Rating Specification			
Phase	Voltage	Max HP	Max Amps
1 PH	120	2	24
1 PH	240	3	17
3 PH	200 - 208	7.5	25.3
3 PH	220 - 240	7.5	22
3 PH	440 - 480	15	21
3 PH	550 - 600	20	22

UNIT DIMENSIONS

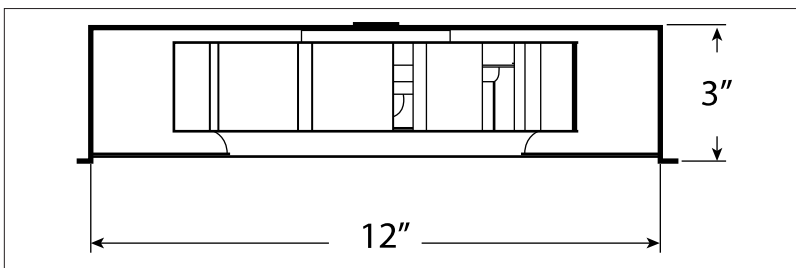

FAN: -FBO-NFPA (PRO) 36"

DUCT LOCATION

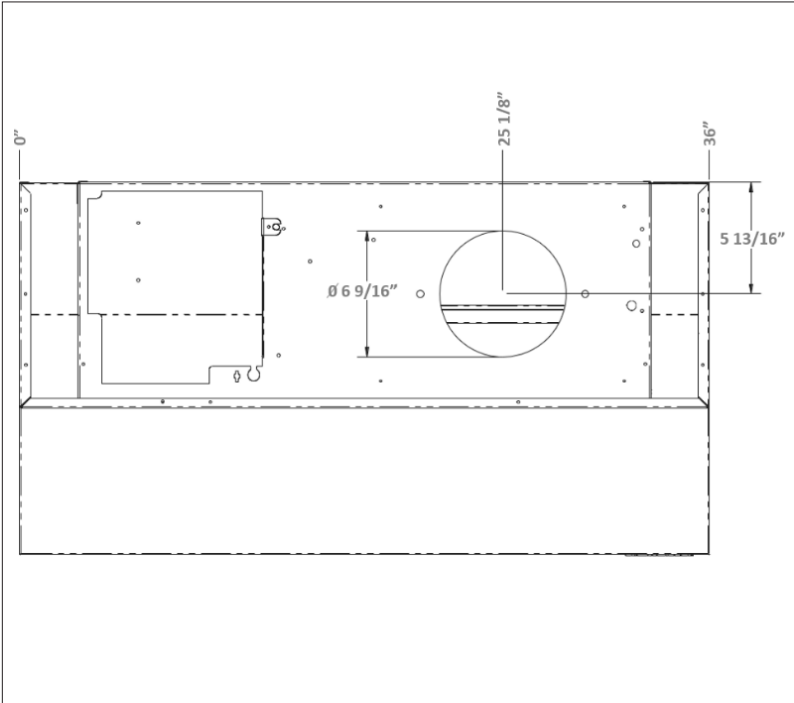

SAMPLE EXHAUST LAYOUT

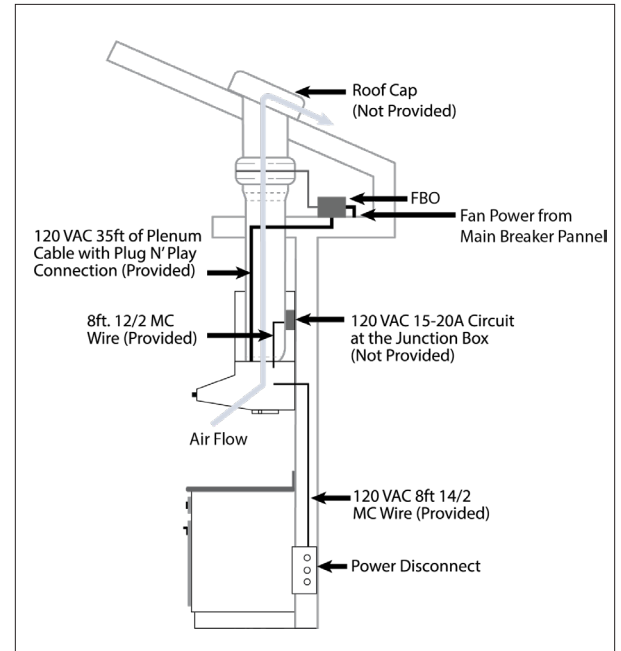

TOP DISCHARGING MOUNTING BRACKET (D1000-BPSI)

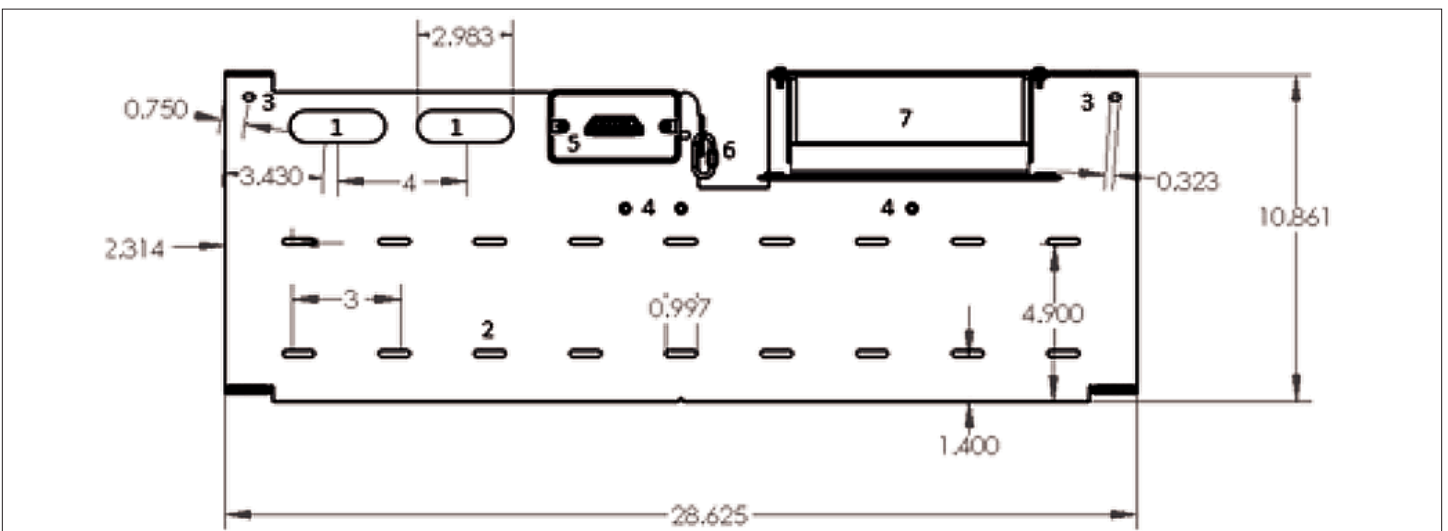

CLOCKBOX™: -CLBX



SPECIFICATIONS

Mounting	Surface Mount or Flush Mount
Weight	14 lbs
Voltage	120 VAC
Phase	1
Frequency	60 Hz
Breaker Size	15 Amps
Operating Current	0.1 Amps
Fuse	0.5 Amps
Touch Screen Voltage	5 DC
Output Current Maximum	2 Amps
Conduit	25 ft 16 mm ENT Conduit

FEATURES

Two Hour Timer	Password Protected	Adjustable Time	Change Password	ADA Compatible	Language Selection	Input/Output To A Monitoring Station/ Alarm System	Interacts with Hood	Displays User Instructions	Displays Hood Faults	Locks Out if There is a Fault with the Hood
Y	Y	Y	Y	N*	N*	N*	N*	N*	N*	N*

* Available with the ClockBox Pro, information is available in the Accessories Booklet.

DIMENSIONS

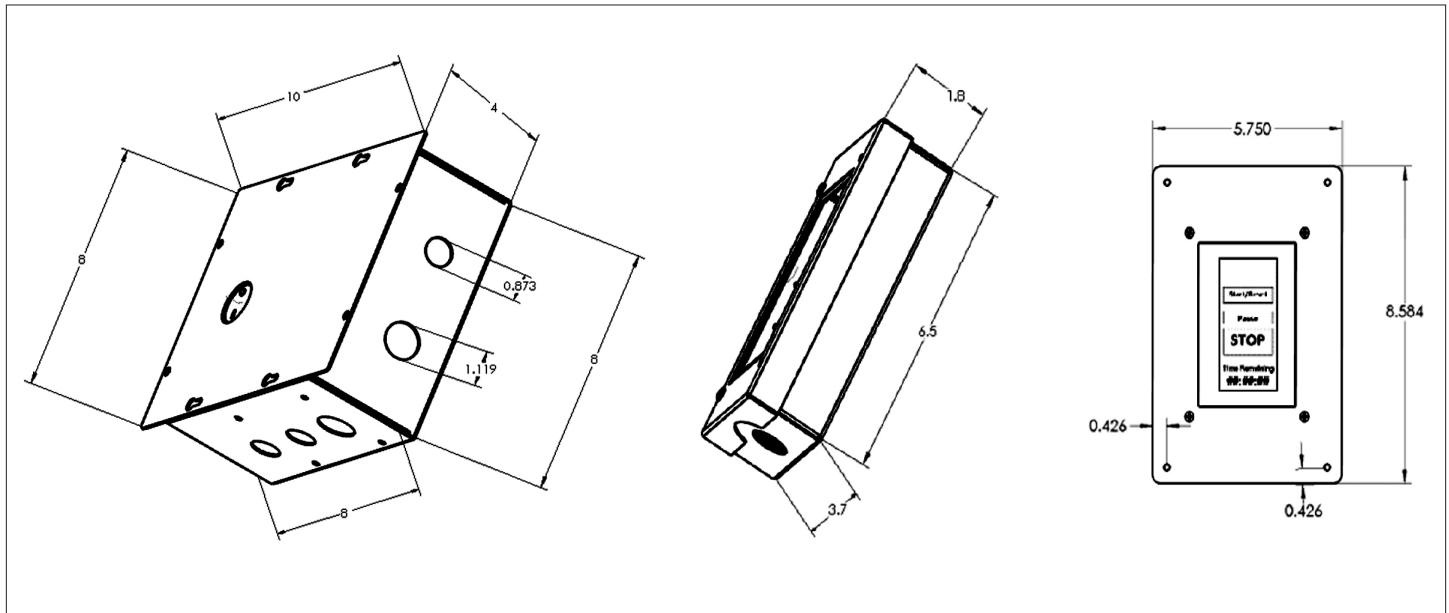

CLOCKBOX™: -CLBX

SCHEMATIC

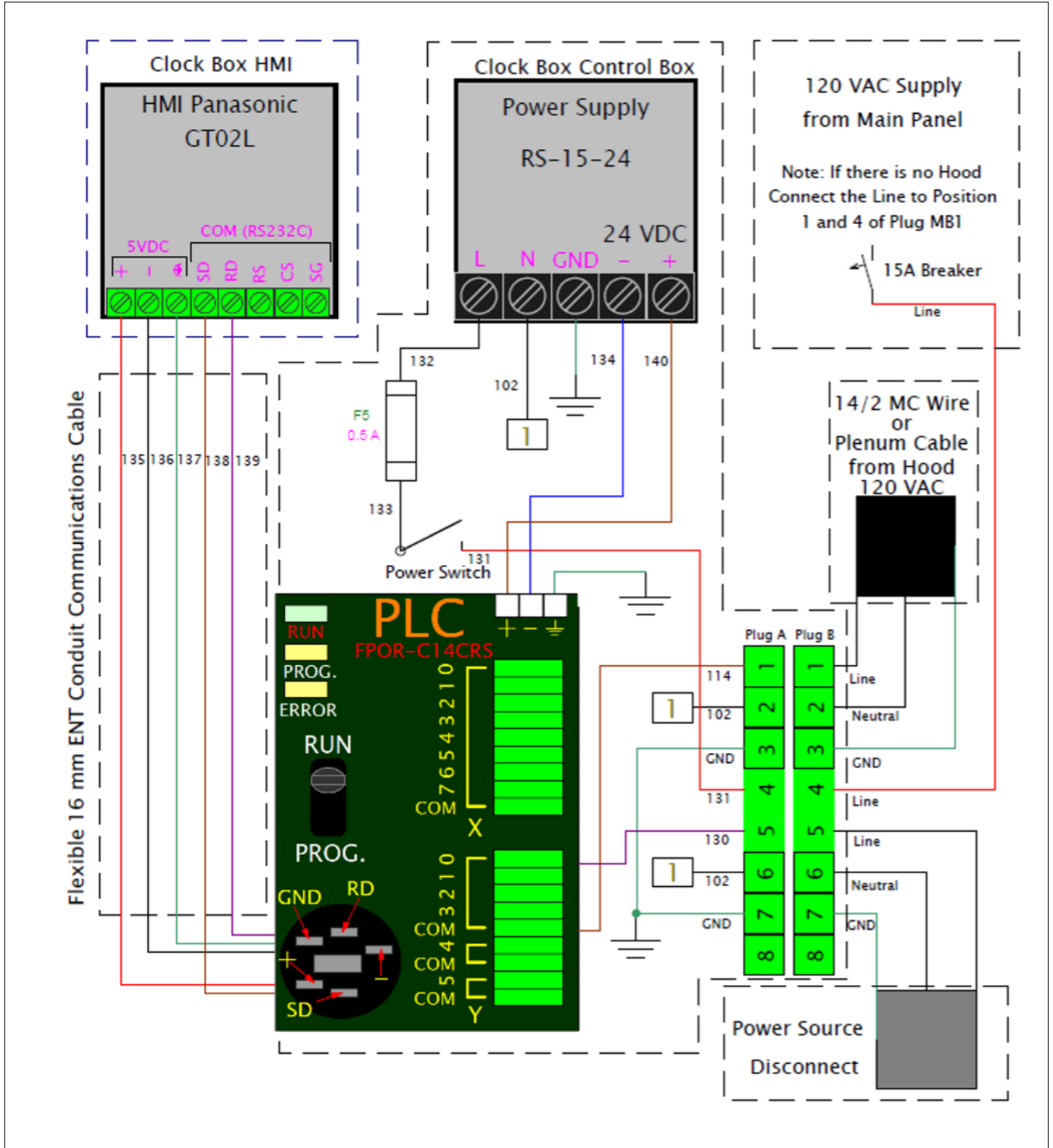

MANUAL PULL STATION: -MPK (D1000)

THE D1000-MPK COMES EQUIPPED WITH THE FOLLOWING



1x Enclosure 4" x 1.5"
Octagon Metal Box



1x Manual Pull
Station Face Plate



1x 1/2" ENT
Conduit Connector



3x 90 Degree
Corner Pulleys



1x 25' Stainless-Steel
Cable with Clevis Pin

The Manual Pull Station (D1000-MPK) is designed to discharge the D1000 Model when a user pulls the tab from the Manual Pull Station Face Plate. The D1000-MPK is provided with 25 feet Stainless-Steel Cable and with three 90 Degree Corner Pulleys. It is required to have 7-10 inches extra Stainless-Steel Cable at the Pull Station Box.

30" MODEL PULL-PIN LOCATION

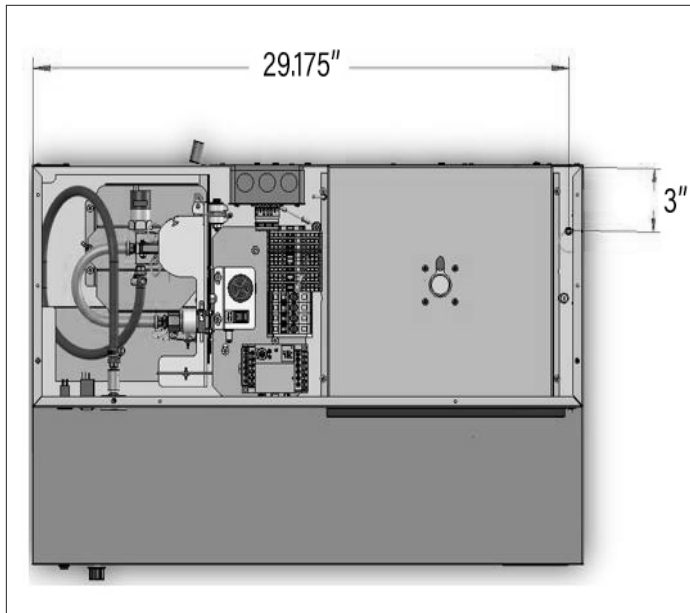

36" MODEL PULL-PIN LOCATION

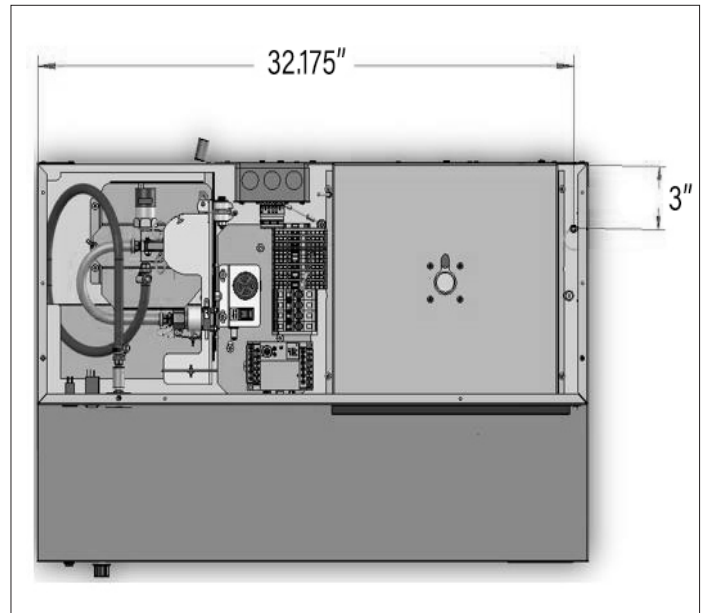

ALARM: INTEGRATED TO D1000

ALARM LOCATION

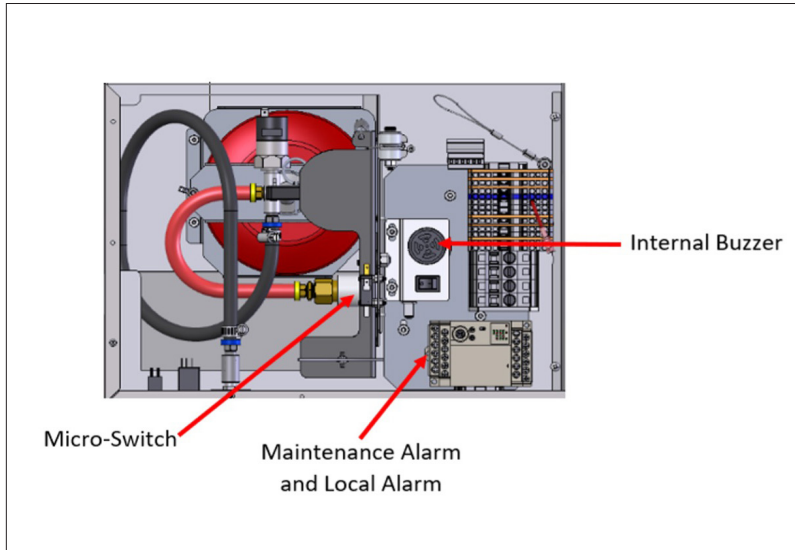

INTERNAL BUZZER SPECIFICATIONS

Type	Audible
Decibels	90
Location	Top center of main unit
Activates upon	Tank discharge hose disconnected, low pressure in tank, or high temp fault (190° F at hood)

MAINTENANCE ALARM SPECIFICATIONS

Type	Dry Contact
Type of Contacts	Com / NO
Contact Amperage	5 Amps
Location	PLC contacts C0 and Y0
Activates upon	Tank discharge hose disconnected, low pressure in tank, or high temp fault (190° F at hood)

MICRO-SWITCH LAYOUT

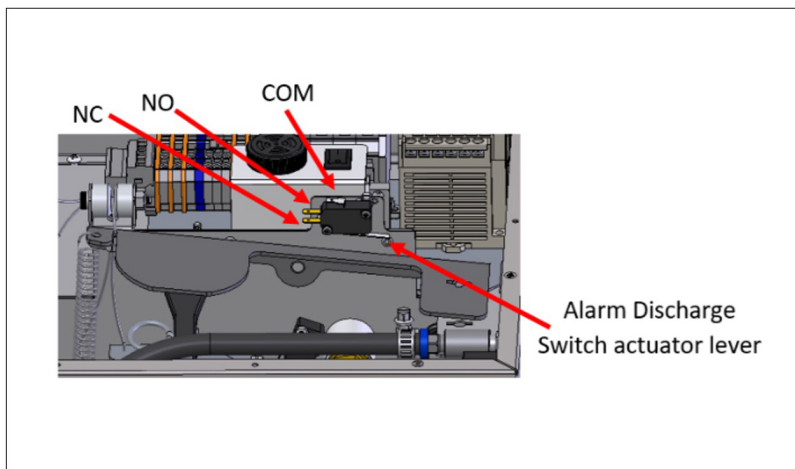

LOCAL ALARM SPECIFICATIONS

Type	Dry Contact
Type of Contacts	Com / NO
Contact Amperage	5 Amps
Location	PLC contacts C1 and Y1
Activates upon	Low pressure in tank, and high temp fault (190° F at hood)

MICRO-SWITCH SPECIFICATIONS

Type	Dry Contact
Type of Contacts	Com / NO / NC
Contact Amperage	15 Amps
Location	Above tank actuation paddle
Activates upon	Mechanical discharge of the tank

SUPPRESSION TANK: -TANK-FC/SA (D1000)

UNIT DIMENSIONS

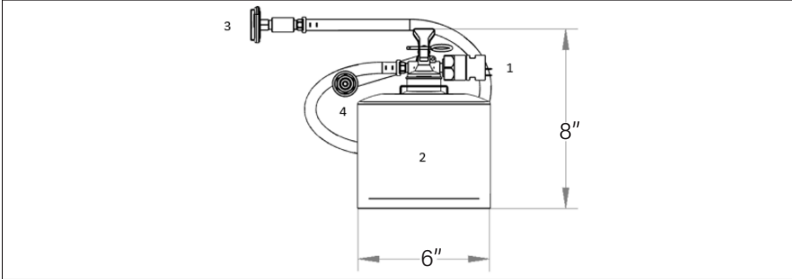

- | | |
|---|---|
| 1 | Tank is Equipped with a Pressure Switch which opens on discharge. |
| 2 | Tank is of Stainless Steel Construction. |
| 3 | Visual Pressure Gauge. |
| 4 | Discharge Hose with Quick Connect fitting attached. |

FC SPECIFICATIONS

Type	Self Contained Fire Suppression System
Compliance	UL-1995
Mounting Configuration	Integral to the hood
Weight	9.4 lbs
Vessel	Stainless Steel
Chemical Type	Amerex 660
Volume	1300 mL
Chemical Weight	2.2 lbs
Pressure (PSI) +-8%	102 PSI
Height	8 in
Width	6 in

NOZZLE PLACEMENT (PRE-INSTALLED IN HOOD)

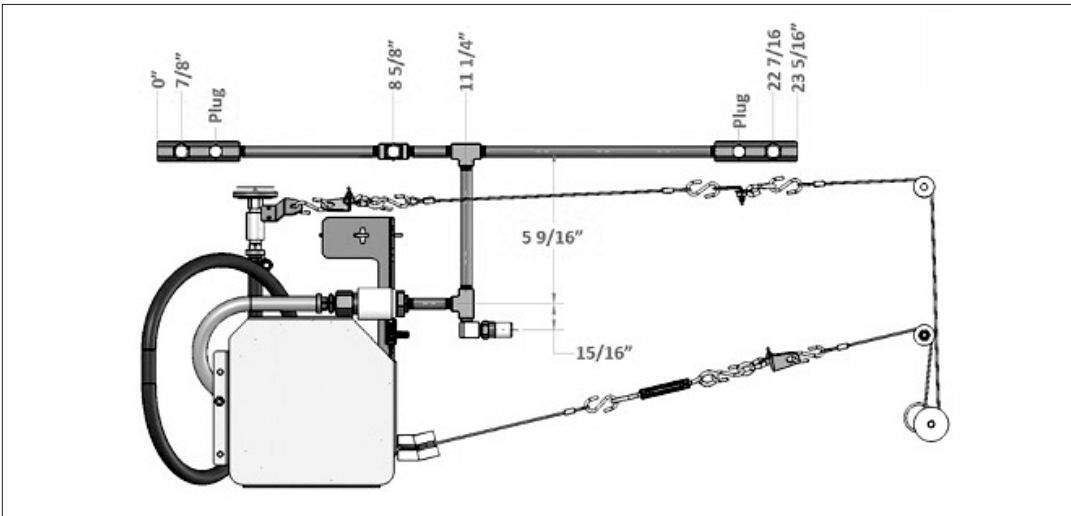

TANK LOCATION

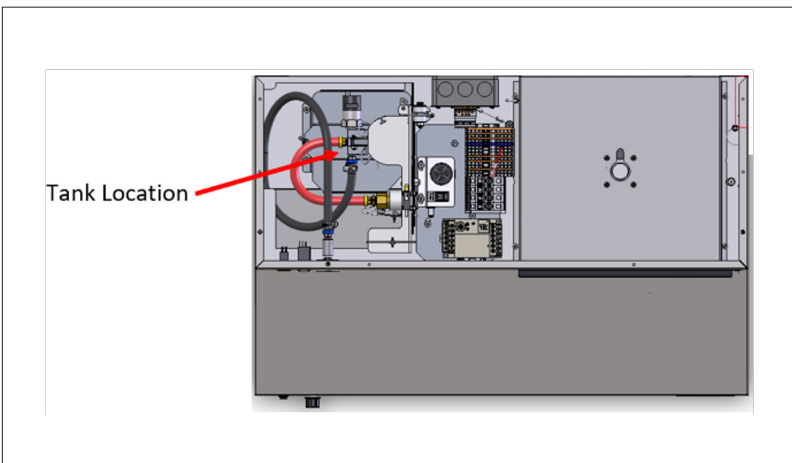

SA SPECIFICATIONS

Type	Self Contained Fire Suppression System
Compliance	UL-1995
Mounting Configuration	Integral to the hood
Weight	9.4 lbs
Vessel	Stainless Steel
Chemical Type	Amerex 660
Volume	1300 mL
Chemical Weight	2.2 lbs
Pressure (PSI) +-8%	Charge to 102 PSI on site
Height	8 in
Width	6 in