

## BASE MODEL: D1030-D-IF-NFPA-PRO

Job Name: \_\_\_\_\_ Date: \_\_\_\_\_ Mark: \_\_\_\_\_

Reference: \_\_\_\_\_ Unit Location: \_\_\_\_\_ Prepared By: \_\_\_\_\_

Engineer: \_\_\_\_\_ Contractor: \_\_\_\_\_ Approval: \_\_\_\_\_

Expected Job Date: \_\_\_\_\_ Notes: \_\_\_\_\_

### MODEL FAN OPTIONS

Integral Fans:  **F** - Recirculating  **R** - Discharging

Top Discharging External Fans:  **FBO** - Fan by Others Module  **IF** - Inline Fan  **RF** - Roof Mounted Fan  **WF** - Wall Mounted Fan

### SELECT OPTIONAL ACCESSORIES

- |   |  |
|---|--|
| <input type="checkbox"/> <b>ADA</b> : ADA Fan/Light Control                                   | <input type="checkbox"/> <b>D1030-TC-D</b> : Top Cover                                 |
| <input type="checkbox"/> <b>CC</b> : Custom Color - (Stainless Standard) Specify Color: _____ | <input type="checkbox"/> <b>MACM</b> : Make-Up Air Control Module                      |
| <input type="checkbox"/> <b>TANK-TEST</b> : Test Tank   | <input checked="" type="checkbox"/> <b>CLBX-PRO</b> : Clockbox Pro with integrated ADA |
| <input checked="" type="checkbox"/> <b>MPK</b> : Manual Pull Station                          | <input type="checkbox"/> <b>STROBE</b> : Horn and Light Strobe Alarm                   |

### RANGE FUEL SOURCE DISCONNECT OPTIONS (CHECK APPROPRIATE RECEPTACLE)

- |  |   |
|--|---|
| <input type="checkbox"/> <b>G</b> : 3/4" NPT Natural Gas (DED Needed if Electric Components Need to be Controlled on a Gas Range)                    | <input type="checkbox"/> <b>DED</b> : Dual Element (includes 3/4" NPT Natural Gas and Electric) -<br>○ 14-50R, 220VAC ○ 5-20R, 120VAC |
| <input checked="" type="checkbox"/> <b>E</b> : Electric -<br>○ 14-50R, 220VAC ○ 6-20R, 220VAC<br>○ 10-50R, 220VAC ○ 5-20R, 120VAC<br>○ 5-15R, 120VAC | <input type="checkbox"/> <b>DRD</b> : Dual Receptacle -<br>○ 6-20R, 220VAC ○ 5-15R, 120VAC ○ 5-20R, 120VAC                            |

### ELECTRIC NEMA (RECEPTACLE) OPTIONS

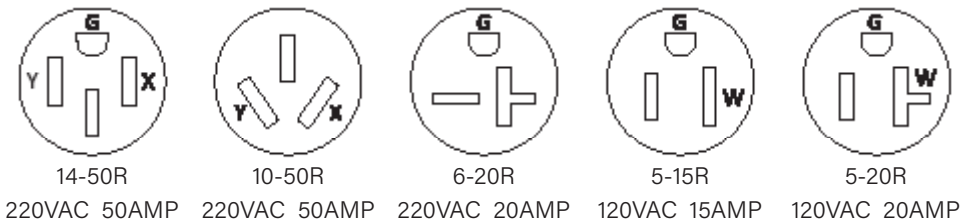

Contact factory for any special circumstances

### REQUIREMENTS

#### Hood shall:

- Be D1000 Series by DENLAR Fire Protection
- Be wall mounted so that the bottom of the mounting bracket sits 24" to 30" above the range
- Be of stainless-steel construction (#18 & #20 GA, polished 304) with no sharp edges and brushed finish
- Have factory installed fire suppression system
- Have 212° F degree fusible link (30") which will activate the mechanical fire suppression system
- Have wet chemical extinguishing agent: Low PH Amerex 660 (pressurized potassium citrate / potassium acetate mix)
- Have centrifugal fan with air delivery
- Be ETL listed, tested to UL300A standard
- Fan motor shall be permanently lubricated and meet UL507 standard
- CFM should achieve at least 500CFM for compliance
- Include a power disconnect for gas and/or electric appliances, deactivated at suppression system discharge
- Automatically disconnect range element once a certain pre-set temperature is reached or under particular predefined events or conditions
- Unit shall have multiple alarm contacts pre-installed (local, remote and trouble alarms) and an audible buzzer
- Lighting shall be by LED bulb

**BASE MODEL: D1030-D-IF-NFPA-PRO**



**GENERAL FEATURES**

- ETL/CSA listed
- 304 Brushed Stainless Steel
- Fail-Safe mechanical actuation
- Two step pre-suppression
- Plenum nozzle
- Main power switch and reset switch
- Service switch
- Pressure switch
- Pressure gauge
- Temperature switches
- Hard wired fuel source disconnect
- Dry alarm contacts
- On board diagnostics
- Status LED
- Trouble signal
- Service key
- Audible buzzer (90db)
- LED bulb
- Grease baffle with drip tray
- Integrated ADA light and fan controls through ClockBox Pro

**UNIT DIMENSIONS**

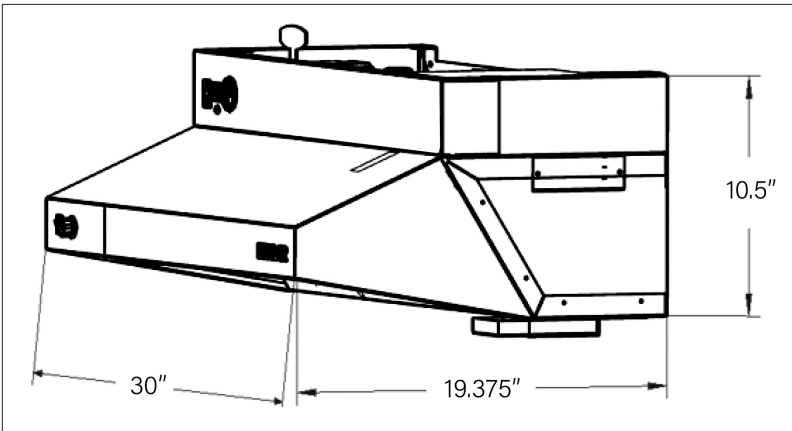

**REQUIRED FOR ALL MODELS**



The main unit requires clearance to tilt to a 45° degree angle for maintenance purposes

**SPECIFICATIONS**

<b>Compliance</b>	UL300A, NSF, UL507, and NFPA101, ADA compliant
<b>Weight</b>	53.4 lbs
<b>Mounting Configuration</b>	Wall
<b>Min / Max Install Height Above Top of Residential Range / Cook Top</b>	24" - 30"
<b>Voltage</b>	120 AC
<b>Phase</b>	1
<b>Hz</b>	60 Hz
<b>Amps</b>	4 Amps
<b>Circuit breaker size</b>	15-20 Amps
<b>Operating Current</b>	3.1 Amps
<b>Fan Operating Current</b>	2.71 Amps
<b>Output Operating Current</b>	0.25 to 0.5 Amps
<b>Input Wiring</b>	Power Cord
<b>Output Wiring</b>	14/2 MC Wire
<b>Fan Type</b>	Inline Fan (Fan is External)
<b>MOCP</b>	15 Amps
<b>Duct Type</b>	See Local Codes
<b>Fire Control</b>	Programmable Logic Controller
<b>Tank Type</b>	Stainless Steel
<b>Tank Pressure</b>	102+/-8% Psi
<b>Tank Volume</b>	1300 mL
<b>Suppression Agent</b>	Low pH Wet Chemical Amerex 660
<b>No. of Nozzles / Spray</b>	5 / 60 Degree Conical
<b>Protection Device / Limit</b>	3 Globe Links / 212° F

**BASE MODEL: D1030-D-IF-NFPA-PRO**

**NOZZLE PLACEMENT**

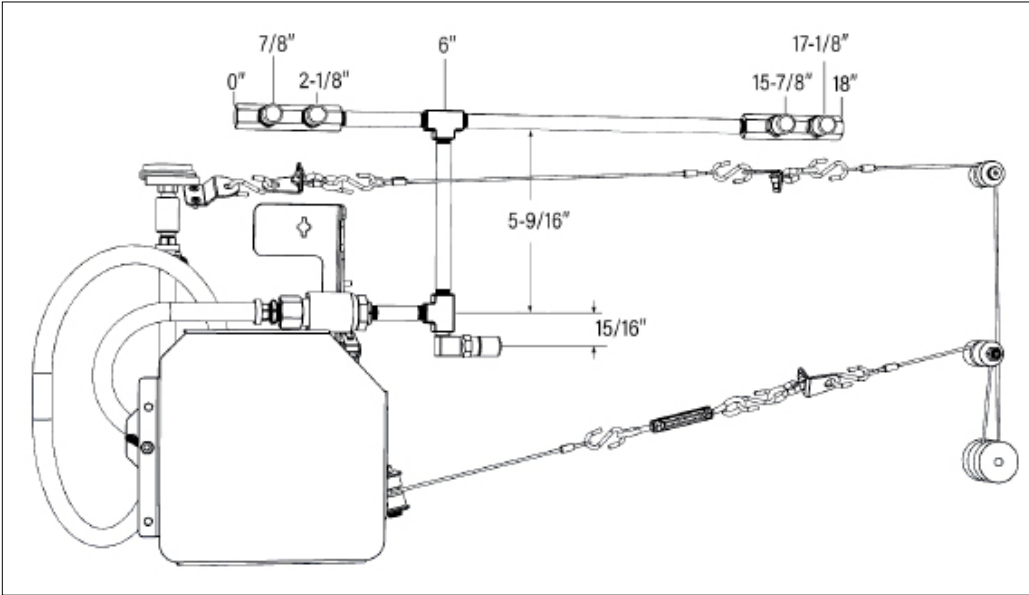

**TOP DUCTED EXHAUST**

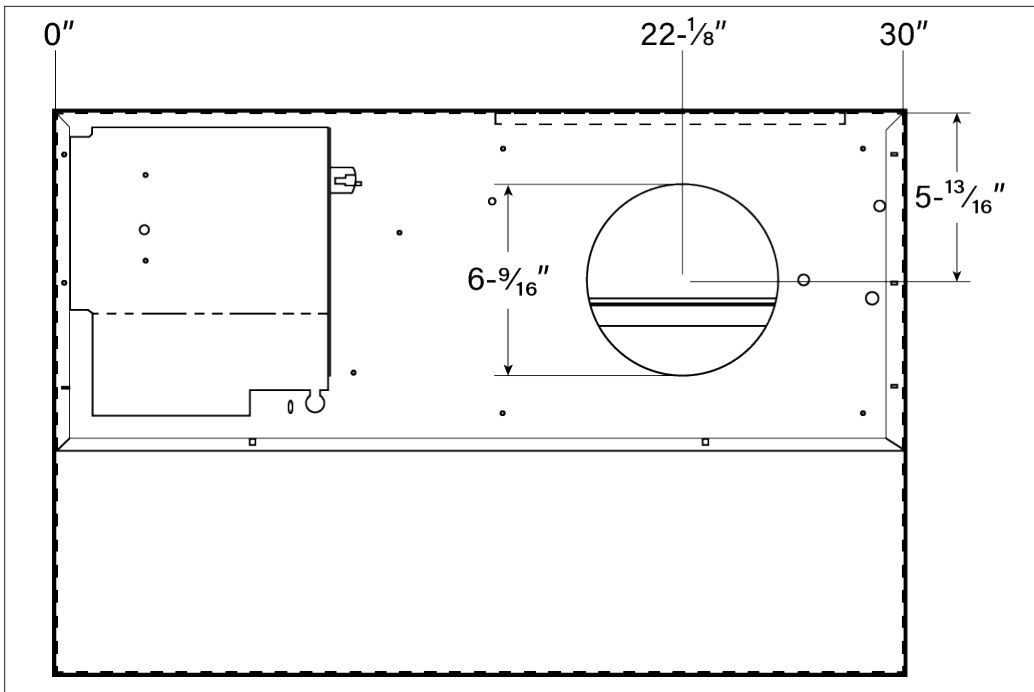

# ELECTRIC STOVE POWER SOURCE DISCONNECT: -E (D1000)

## ELECTRIC RECEPTACLE DIMENSIONS

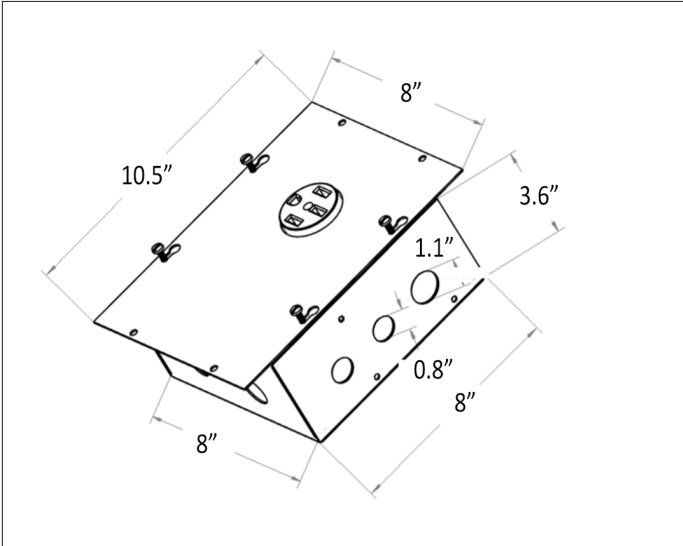

## SPECIFICATIONS

Models	-E-220 14-50	-E-220 10-50	-E 220 6-20	-E-120 5-20	-E-120 5-15
Weight	5.4 lbs.				
NEMA	14-50R	10-50R	6-20R	5-20R	5-15R
Output Volts	220 AC	220 AC	220 AC	120 AC	120 AC
Output Current	50 Amps	50 Amps	20 Amps	20 Amps	15 Amps
Coil Voltage	120				
Phase	1				
Frequency	60 Hz				
Fuse	0.5 Amps				
Fuse Type	5 X 20mm Cartridge				
Operating Current	0.25 Amps				
Material	Galvanized				
Mounting Type	Surface or flush mount				
Mounting Height	See local codes				

## SCHEMATIC

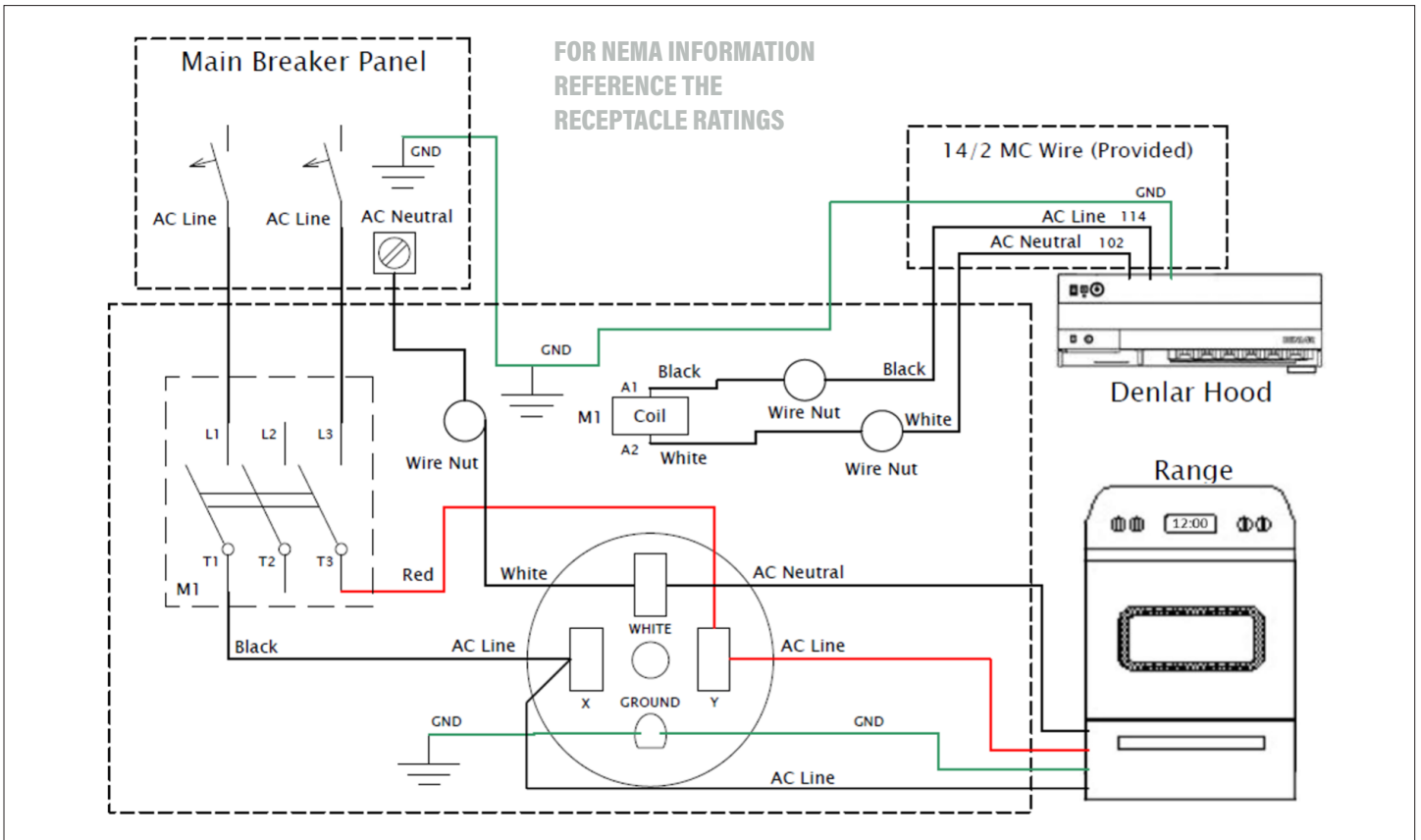

# FAN: -D-IF-NFPA (PRO) 30"

## NFPA INLINE DIMENSIONS

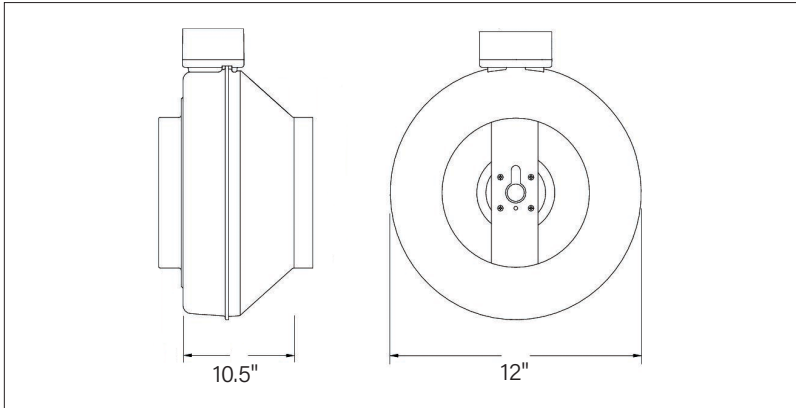

## SPECIFICATIONS

Style	Inline
Type	Ducted
Weight	13.5 lbs
Operating Current	2.5 Amps
Voltage	120 AC
Phase	1
Frequency	60 Hz
CFM + -2.5% (Low-High)	297 - 545
Pressure (In Water)	-0.29 - -0.89
dB(A) (Low-High)	60 - 70
Hood Outlet (Length-Height)	7 in (Dia)
Duct	35 ft
Fan Inlet	12 in (Dia)
Fan Outlet	12 in (Dia)
Control	Electronic Control Module (ECM)
Speeds	Variable

D1000-BPSI Layout	
1	Cut-outs for Wire Entry
2	Mounting Holes
3	Top Mounting Holes
4	1/4-20 Studs for Securing Hoods to D1000-BPSI
5	Handy box for Power In and Power Out
6	Quick Link Safety Cable Holder
7	Collar to Attach Duct Work (7" Dia. X 1" Height) (A Minimum of 6" length of 7" Dia. Duct is required before connecting an Increaser/Adapter)

## TOP DISCHARGING MOUNTING BRACKET (D1000-BPSI)

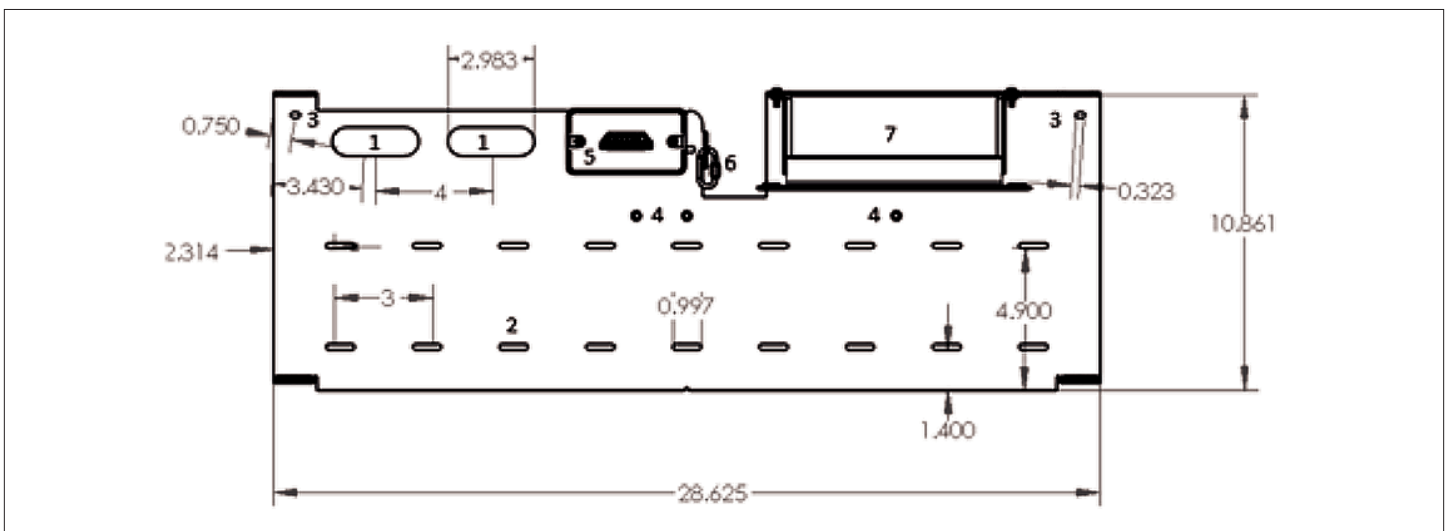

# FAN: -D-IF-NFPA (PRO) 30"

## DUCT LOCATION

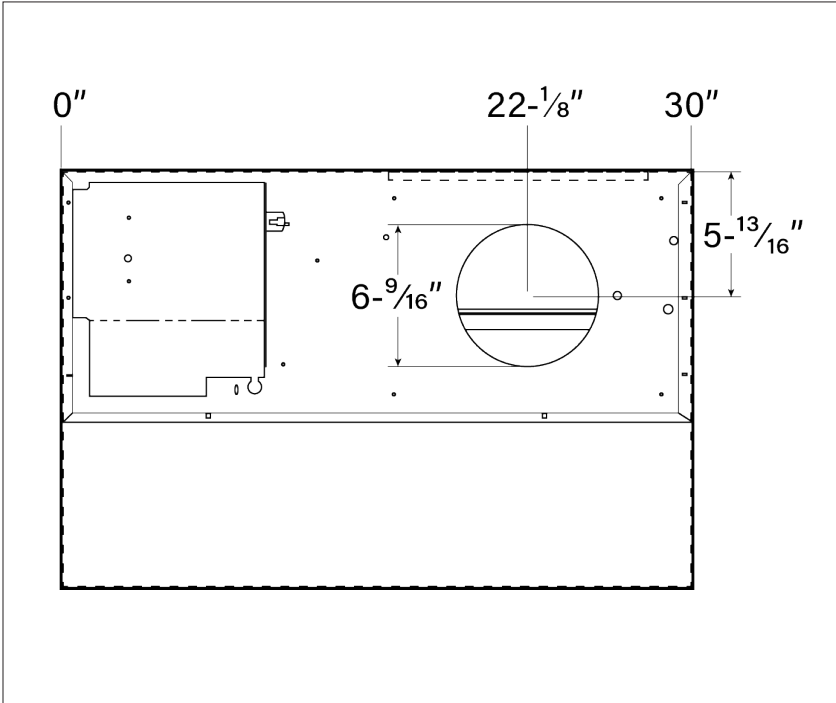

## SAMPLE EXHAUST LAYOUT

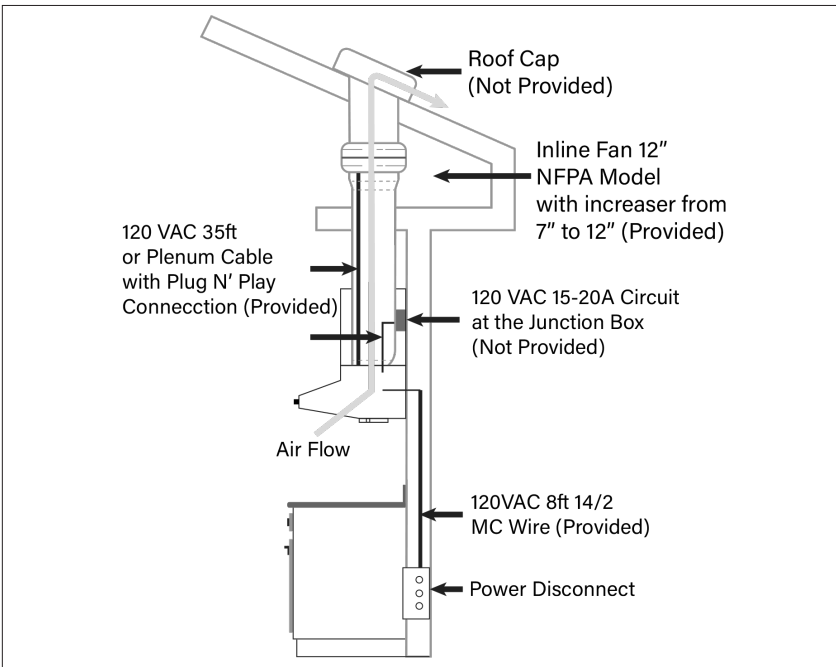

# CLOCKBOX PRO™: -CLBX-PRO



## SPECIFICATIONS

Mounting	Surface Mount or Flush Mount
Weight	18 lbs
Voltage	120 VAC
Phase	1
Frequency	60 Hz
Breaker Size (Amps)	15 A
Operating Current (Amps)	0.1 A
Fuse (Amps)	1 A
Output Current Maximum (Amps)	10 A
Touch Screen Voltage	24 DC
Conduit	25 ft 16 mm Flexible ENT Conduit

## FEATURES

Two Hour Timer	Password Protected	Adjustable Time	Change Password	ADA Compatible	Language Selection	Input/Output To A Monitoring Station/ Alarm System	Interacts with Hood	Displays User Instructions	Displays Hood Faults	Locks Out if There is a Fault with the Hood
Y	Y	Y	Y	Y	Y	Y	Y	Y	Y	Y

## UNIT DIMENSIONS

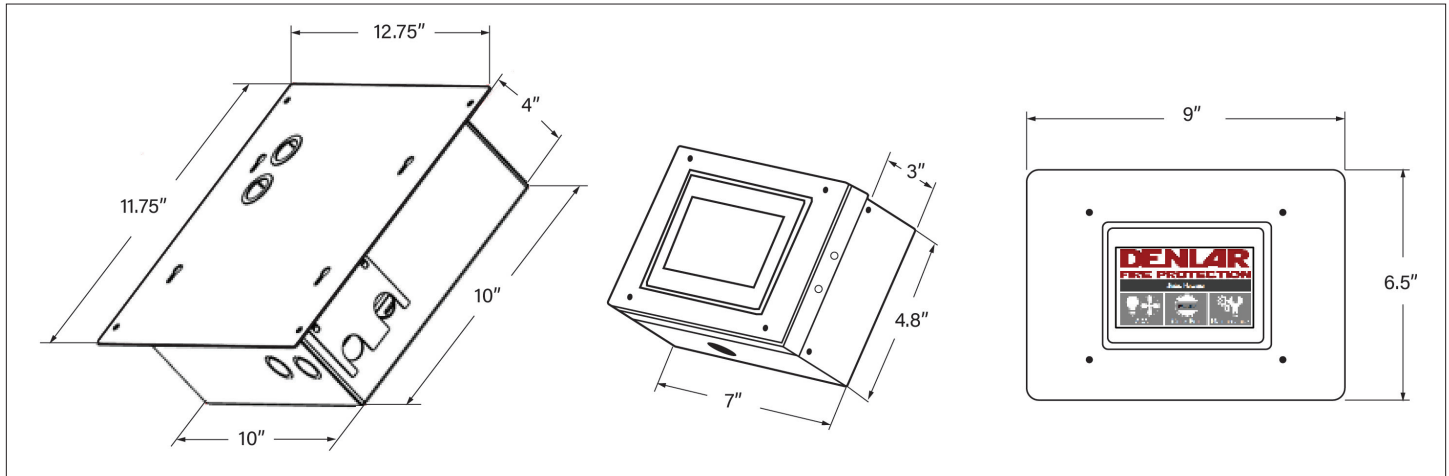

**CLOCKBOX PRO™: -CLBX-PRO**

**SCHEMATIC**

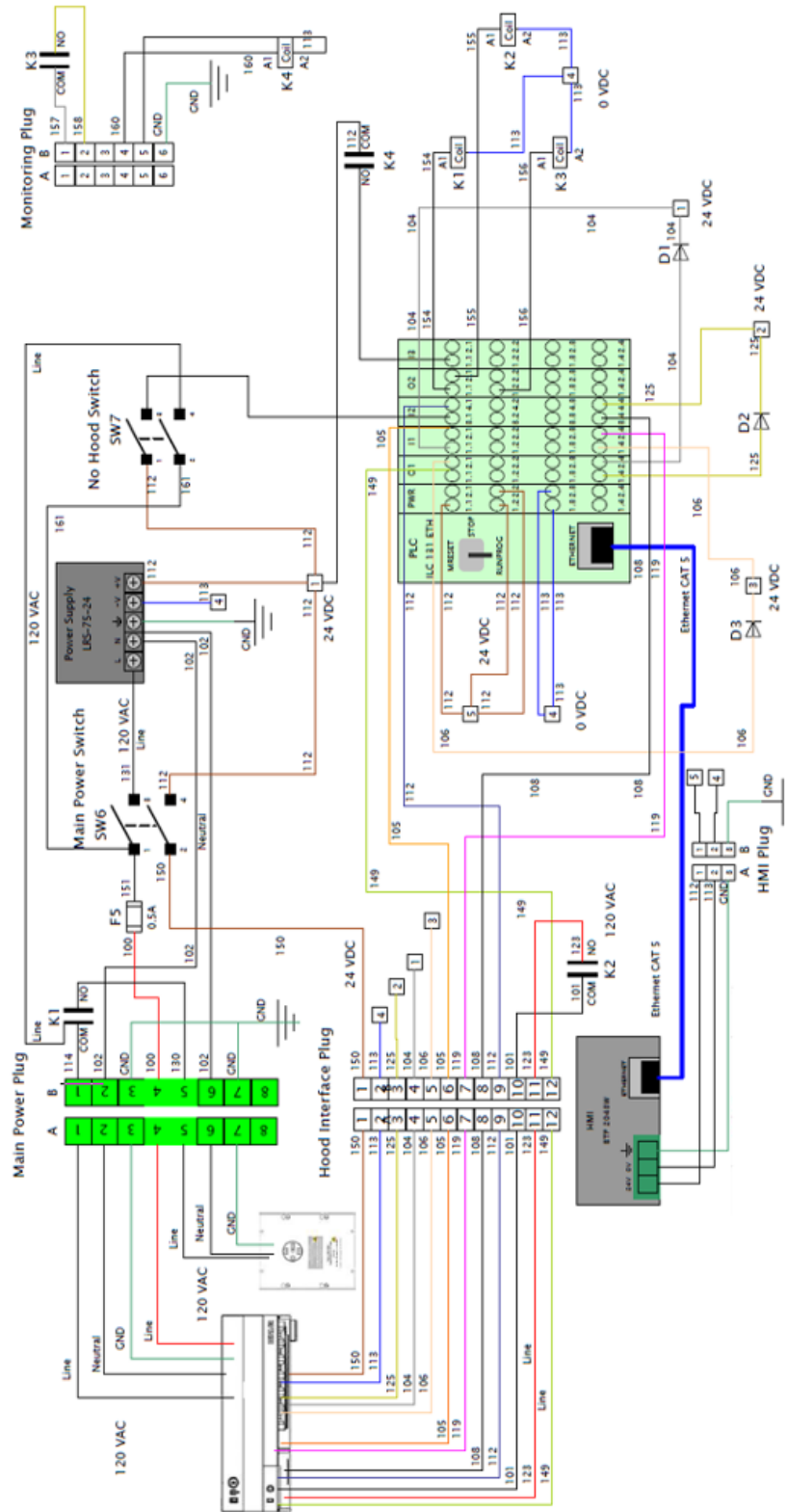



# MANUAL PULL STATION: -MPK (D1000)

**THE D1000-MPK COMES EQUIPPED WITH THE FOLLOWING**



1x Enclosure 4" x 1.5"  
Octagon Metal Box



1x Manual Pull  
Station Face Plate



1x 1/2" ENT  
Conduit Connector

The Manual Pull Station (D1000-MPK) is designed to discharge the D1000 Model when a user pulls the tab from the Manual Pull Station Face Plate. The D1000-MPK is provided with 25 feet Stainless-Steel Cable and with three 90 Degree Corner Pulleys. It is required to have 7-10 inches extra Stainless-Steel Cable at the Pull Station Box.



3x 90 Degree  
Corner Pulleys



1x 25' Stainless-Steel  
Cable with Clevis Pin

**30" MODEL PULL-PIN LOCATION**



**36" MODEL PULL-PIN LOCATION**



# ALARM: INTEGRATED TO D1000

## ALARM LOCATION

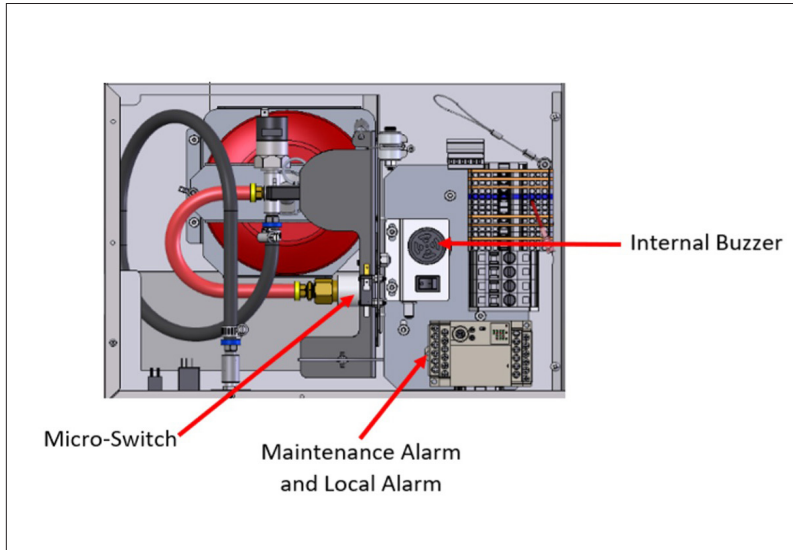

## INTERNAL BUZZER SPECIFICATIONS

Type	Audible
Decibels	90
Location	Top center of main unit
Activates upon	Tank discharge hose disconnected, low pressure in tank, or high temp fault (190° F at hood)

## MAINTENANCE ALARM SPECIFICATIONS

Type	Dry Contact
Type of Contacts	Com / NO
Contact Amperage	5 Amps
Location	PLC contacts C0 and Y0
Activates upon	Tank discharge hose disconnected, low pressure in tank, or high temp fault (190° F at hood)

## MICRO-SWITCH LAYOUT

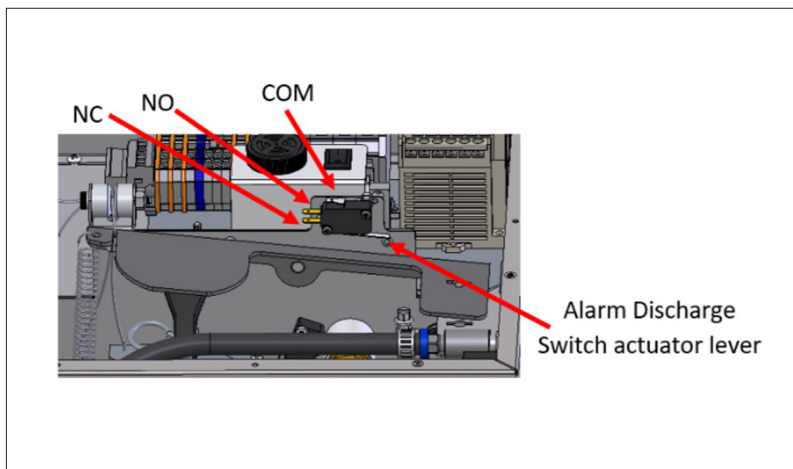

## LOCAL ALARM SPECIFICATIONS

Type	Dry Contact
Type of Contacts	Com / NO
Contact Amperage	5 Amps
Location	PLC contacts C1 and Y1
Activates upon	Low pressure in tank, and high temp fault (190° F at hood)

## MICRO-SWITCH SPECIFICATIONS

Type	Dry Contact
Type of Contacts	Com / NO / NC
Contact Amperage	15 Amps
Location	Above tank actuation paddle
Activates upon	Mechanical discharge of the tank

# SUPPRESSION TANK: -TANK-FC/SA (D1000)

## UNIT DIMENSIONS

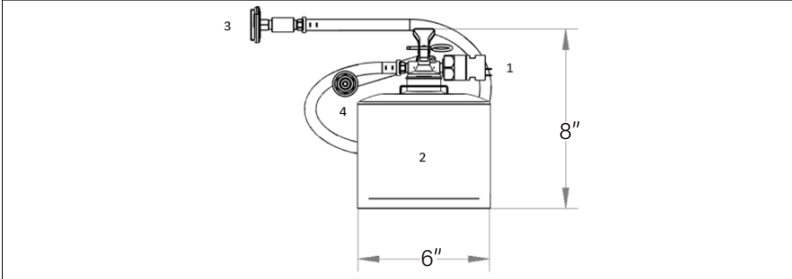

- |   |   |
|---|---|
| 1 | Tank is Equipped with a Pressure Switch which opens on discharge. |
| 2 | Tank is of Stainless Steel Construction.                          |
| 3 | Visual Pressure Gauge.  |
| 4 | Discharge Hose with Quick Connect fitting attached.               |

## FC SPECIFICATIONS

Type	Self Contained Fire Suppression System
Compliance	UL-1995
Mounting Configuration	Integral to the hood
Weight	9.4 lbs
Vessel	Stainless Steel
Chemical Type	Amerex 660
Volume	1300 mL
Chemical Weight	2.2 lbs
Pressure (PSI) +-8%	102 PSI
Height	8 in
Width	6 in

## NOZZLE PLACEMENT (PRE-INSTALLED IN HOOD)

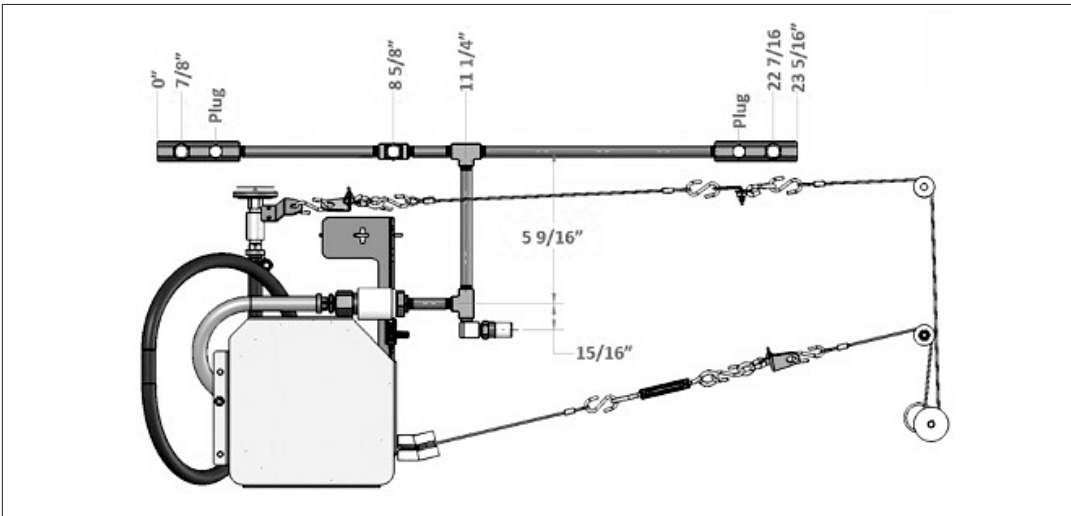

## TANK LOCATION

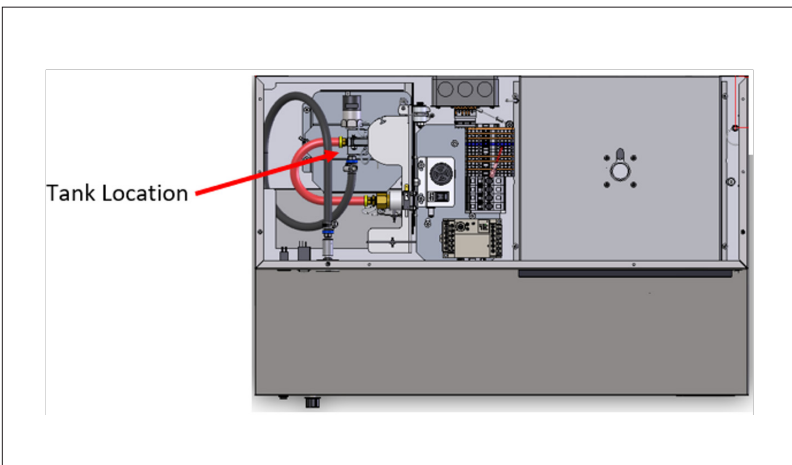

## SA SPECIFICATIONS

Type	Self Contained Fire Suppression System
Compliance	UL-1995
Mounting Configuration	Integral to the hood
Weight	9.4 lbs
Vessel	Stainless Steel
Chemical Type	Amerex 660
Volume	1300 mL
Chemical Weight	2.2 lbs
Pressure (PSI) +-8%	Charge to 102 PSI on site
Height	8 in
Width	6 in