

BASE MODEL: D1030-D-WF

Job Name: _____ Date: _____ Mark: _____

Reference: _____ Unit Location: _____ Prepared By: _____

Engineer: _____ Contractor: _____ Approval: _____

Expected Job Date: _____ Notes: _____

MODEL FAN OPTIONS

Integral Fans: **F** - Recirculating **R** - Rear Discharging
 Top Discharging External Fans: **FBO** - Fan by Others Module **IF** - Inline Fan **RF** - Roof Mounted Fan **WF** - Wall Mounted Fan

SELECT OPTIONAL ACCESSORIES

- | | |
|--|--|
| <input type="checkbox"/> ADA: ADA Fan/Light Control | <input type="checkbox"/> MACM: Make-Up Air Control Module |
| <input type="checkbox"/> CLBX: ClockBox | <input type="checkbox"/> LSC: Limiting Speed Control Module |
| <input type="checkbox"/> CC: Custom Color - (Stainless Standard) Specify Color: _____ | <input type="checkbox"/> CLBX-PRO: Clockbox Pro with integrated ADA |
| <input type="checkbox"/> TANK-TEST: Test Tank | <input type="checkbox"/> STROBE: Horn and Light Strobe Alarm |
| <input type="checkbox"/> MPK: Manual Pull Station | <input type="checkbox"/> PD4X: Power Distribution Box |
| <input type="checkbox"/> D1030-TC-D: Top Cover | |

RANGE FUEL SOURCE DISCONNECT OPTIONS (CHECK APPROPRIATE RECEPTACLE)

- | | |
|--|---|
| <input type="checkbox"/> G: 3/4" NPT Natural Gas (DED Needed if Electric Components Need to be Controlled on a Gas Range) | <input checked="" type="checkbox"/> DED: Dual Element (includes 3/4" NPT Natural Gas and Electric) -
<input type="radio"/> 14-50R, 220VAC <input type="radio"/> 5-20R, 120VAC |
| <input type="checkbox"/> E: Electric -
<input type="radio"/> 14-50R, 220VAC <input type="radio"/> 6-20R, 220VAC
<input type="radio"/> 10-50R, 220VAC <input type="radio"/> 5-20R, 120VAC
<input type="radio"/> 5-15R, 120VAC | <input type="checkbox"/> DRD: Dual Receptacle -
<input type="radio"/> 6-20R, 220VAC <input type="radio"/> 5-15R, 120VAC <input type="radio"/> 5-20R, 120VAC |

ELECTRIC NEMA (RECEPTACLE) OPTIONS

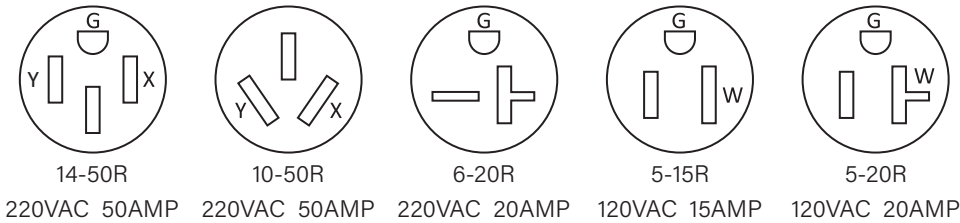

REQUIREMENTS

Contact factory for any special circumstances

Hood shall:

- Be D1000 Series by DENLAR Fire Protection
- Be wall mounted so that the bottom of the mounting bracket sits 24" to 30" above the range
- Be of stainless-steel construction (#18 & #20 GA, polished 304) with no sharp edges and brushed finish
- Have factory installed fire suppression system
- Have 212° F degree fusible link (30") which will activate the mechanical fire suppression system
- Have wet chemical extinguishing agent: Low PH Amerex 660 (pressurized potassium citrate / potassium acetate mix)
- Have centrifugal fan with air delivery
- Be ETL listed, tested to UL300A standard
- Fan motor shall be permanently lubricated and meet UL507 standard
- Include a power disconnect for gas and/or electric appliances, deactivated at suppression system discharge
- Automatically disconnect range element once a certain pre-set temperature is reached or under particular predefined events or conditions
- Unit shall have multiple alarm contacts pre-installed (local, remote and trouble alarms) and an audible buzzer
- Lighting shall be by LED bulb

BASE MODEL: D1030-D-WF



GENERAL FEATURES

- ETL/CSA listed
- 304 Brushed Stainless Steel
- Fail-Safe mechanical actuation
- Two step pre-suppression
- Plenum nozzle
- Main power switch and reset switch
- Service switch
- Pressure switch
- Pressure gauge
- Temperature switches
- Hard wired fuel source disconnect
- Dry alarm contacts
- On board diagnostics
- Status LED
- Trouble signal
- Service key
- Audible buzzer (90db)
- LED bulb
- Grease baffle with drip tray

UNIT DIMENSIONS

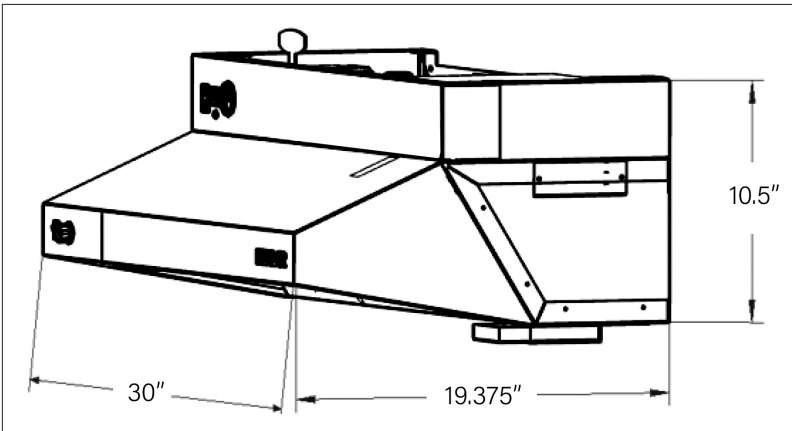

REQUIRED FOR ALL MODELS

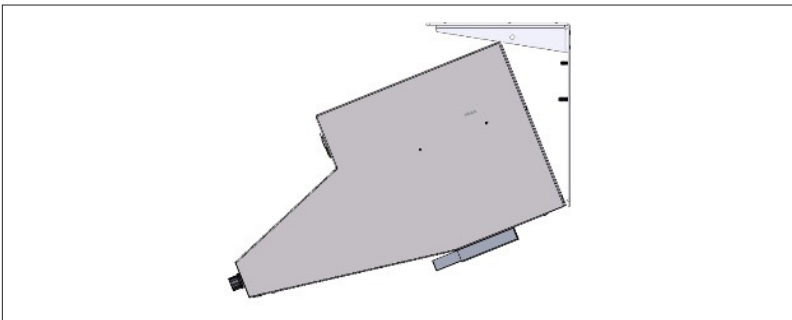

The main unit requires clearance to tilt to a 45° degree angle for maintenance purposes

SPECIFICATIONS

Compliance	UL300A, NSF, UL507
Weight	53.4 lbs
Mounting Configuration	Wall
Min / Max Install Height Above Top of Residential Range / Cook Top	24" - 30"
Voltage	120 AC
Phase	1
Hz	60 Hz
Amps	3.15 Amps
Circuit breaker size	15-20 Amps
Operating Current	1.38 Amps
Fan Operating Current	0.87 Amps
Output Operating Current	0.25 to 0.5 Amps
Input Wiring	Power Cord
Output Wiring	14/2 MC Wire
Fan Type	Wall Mounted Fan (Fan is External)
MOCP	15 Amps
Duct Type	See Local Codes
Fire Control	Programmable Logic Controller
Tank Type	Stainless Steel
Tank Pressure	102+ -8% Psi
Tank Volume	1300 mL
Suppression Agent	Low pH Wet Chemical Amerex 660
No. of Nozzles / Spray	5 / 60 Degree Conical
Protection Device / Limit	3 Globe Links / 212° F

BASE MODEL: D1030-D-WF

NOZZLE PLACEMENT

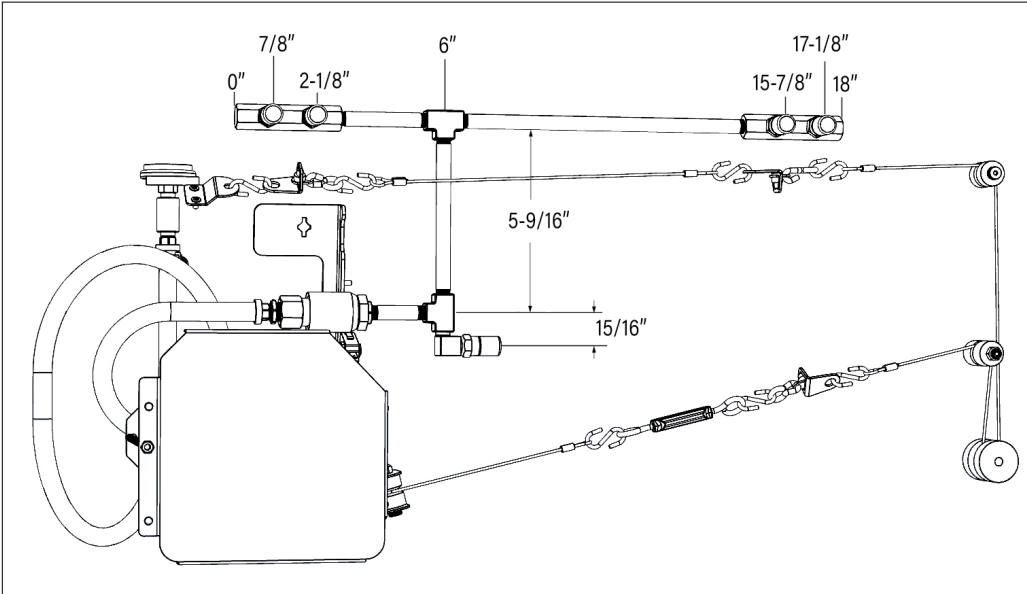

TOP DUCTED EXHAUST

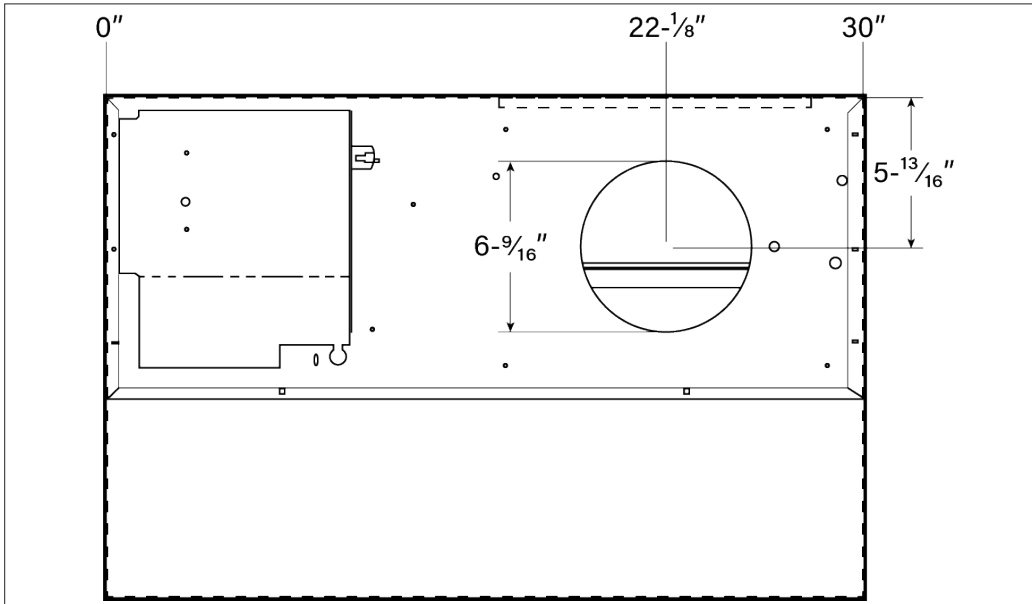

DUAL ELEMENT POWER SOURCE DISCONNECT: -DED (D1000)

ELECTRIC RECEPTACLE DIMENSIONS

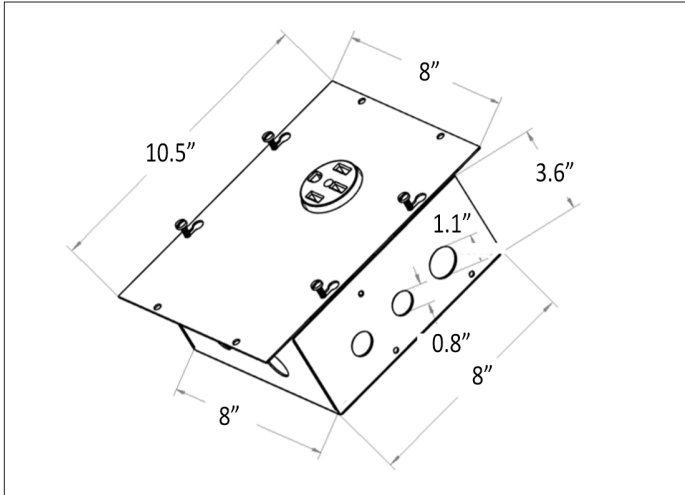

ELECTRIC RECEPTACLE SPECIFICATIONS

Models	-DED-220 14-50	-DED 120 5-20
Weight	5.4 lbs.	
NEMA	14-50 R	5-20 R
Output Volts	220 AC	120 AC
Output Current	50 Amps	20 Amps
Coil Voltage	120	
Phase	1	
Frequency	60 Hz	
Fuse	0.5 Amps	
Fuse Type	5 X 20mm cartridge	
Operating Current	0.25 Amps	
Material	Galvanized	
Mounting Type	Surface or flush mount	
Mounting Height	See local codes	

GAS VALVE DIMENSIONS

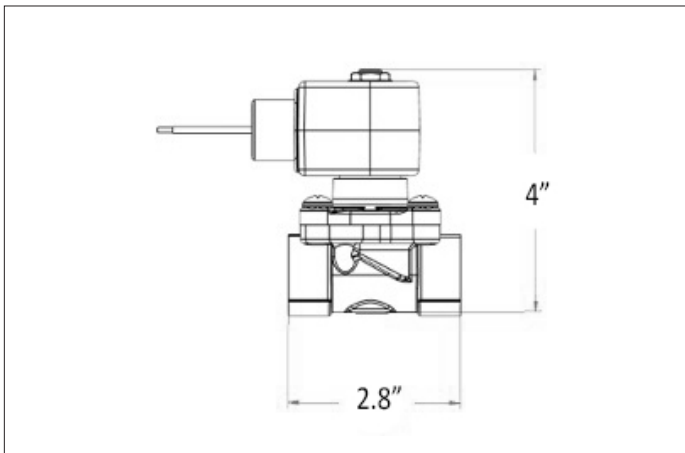

GAS VALVE SPECIFICATIONS

Coil Voltage	120 AC
Phase	1
Frequency	60 Hz
Fuse	0.5 Amps
Operating Current	0.25 Amps
Valve Type	2-Way
Function	Normally closed
Actuation Type Coil Type	Direct lift
Coil Type	½" NPT conduit, 18' leads, class F, NEMA 4X
Body Material	Brass
Seal Material	NBR
Orifice Size	7/16"
Port Size	¾"
Number Of Ports	2
Port Type	NPT
Media	General purpose for air, liquids, and gases
Min. Pressure Differential	0 PSI
Max. Pressure Differential	100 PSI (AC) PSI
Min. Fluid Temperature	0° F
Max. Fluid Temperature	185° F
Flow Coefficient	5 CV

DUAL ELEMENT POWER SOURCE DISCONNECT: -DED

SCHEMATIC

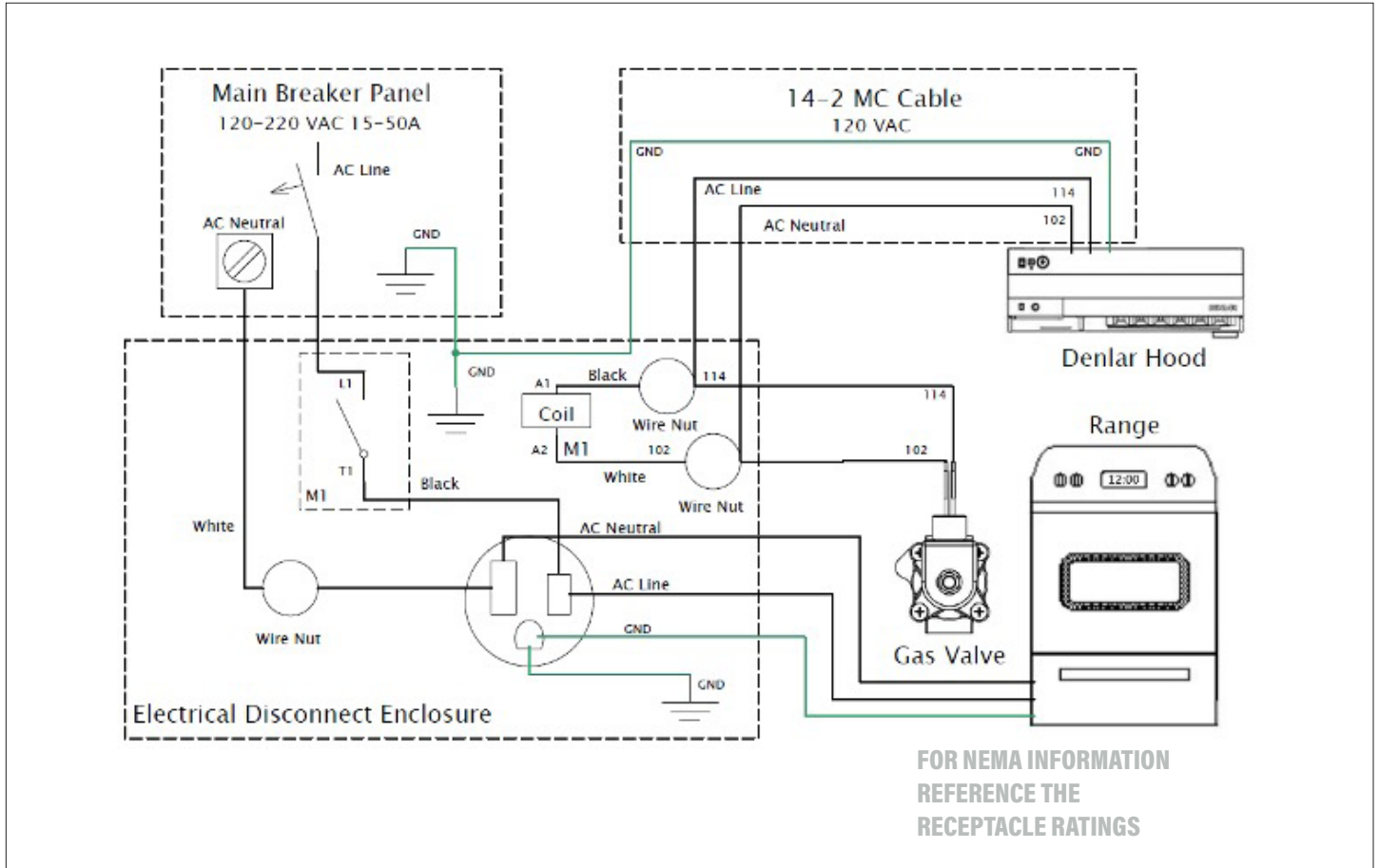

FAN: -D-WF (D1000) 30"

STANDARD WALL MOUNT DIMENSIONS

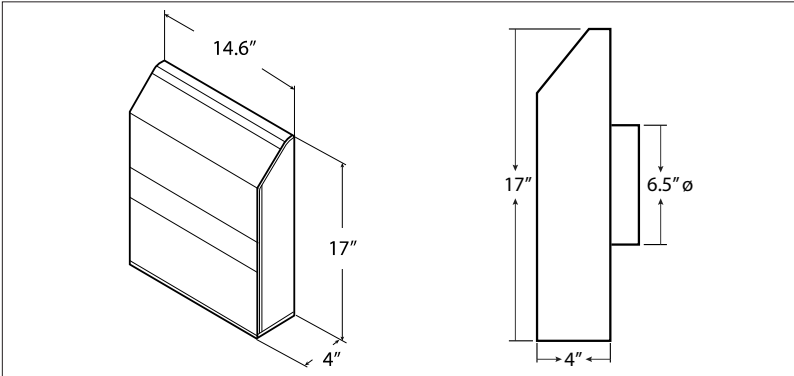

SPECIFICATIONS

Style	Wall Mount
Type	External Wall Ducted
Weight	13.5 lbs
Operating Current	0.8 Amps
Voltage	120 AC
Phase	1
Frequency	60 Hz
CFM + -2.5% (Low-High)	208 - 281
Pressure (In Water)	-0.14 - -0.28
dB(A) (Low-High)	56 - 60
Hood Outlet (Length-Height)	7 in (Dia)
Duct	35 ft
Fan Inlet	6.5 in (Dia)
Fan Outlet	14 in x 3 in
Control	Electronic Control Module (ECM)
Speeds	Variable

D1000-BPSI Layout	
1	Cut-outs for Wire Entry
2	Mounting Holes
3	Top Mounting Holes
4	1/4-20 Studs for Securing Hoods to D1000-BPSI
5	Handy box for Power In and Power Out
6	Quick Link Safety Cable Holder
7	Collar to Attach Duct Work (7" Dia. X 1" Height) (A Minimum of 6" length of 7" Dia. Duct is required before connecting an Increaser/Adapter)

TOP DISCHARGING MOUNTING BRACKET (D1000-BPSI)

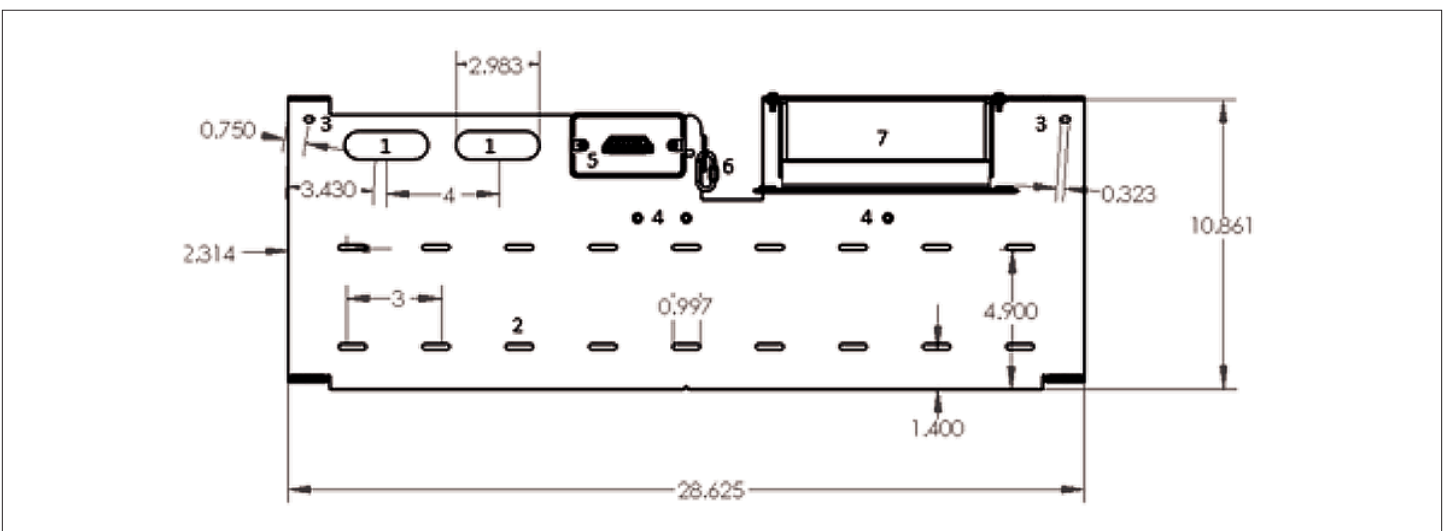

FAN: -D-WF (D1000) 30"

DUCT LOCATION

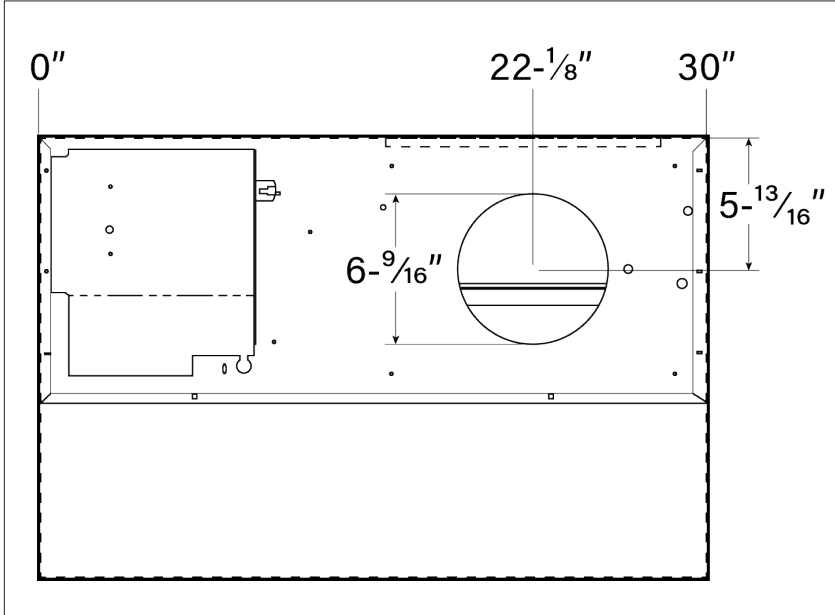

SAMPLE EXHAUST LAYOUT

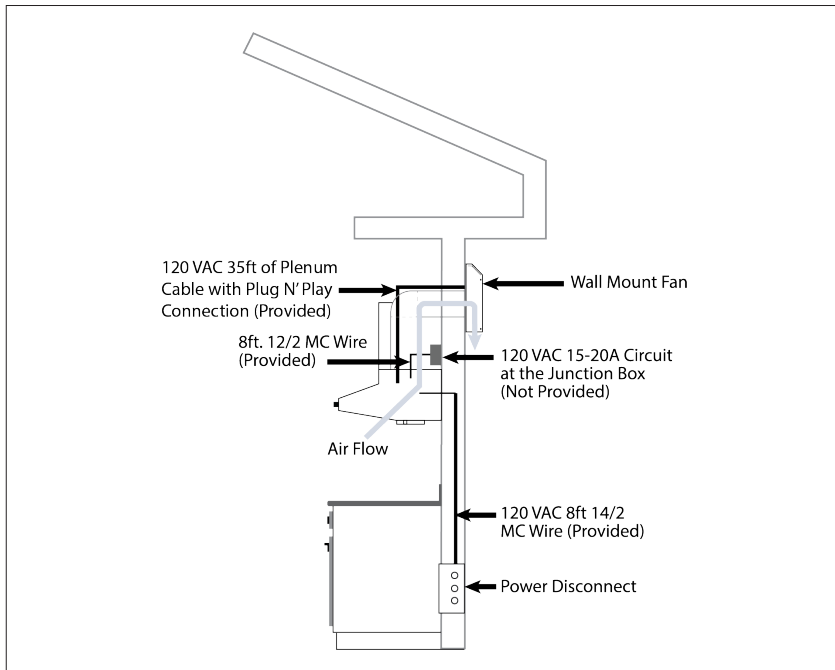

ALARM: INTEGRATED TO D1000

ALARM LOCATION

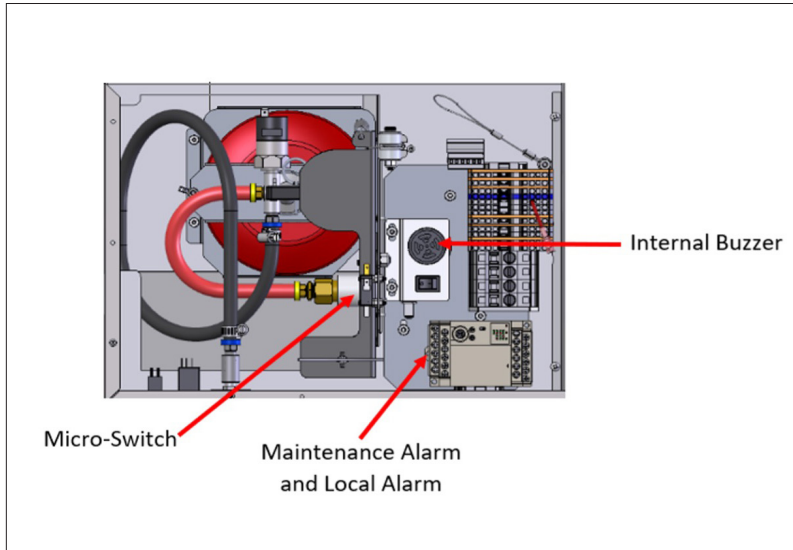

INTERNAL BUZZER SPECIFICATIONS

Type	Audible
Decibels	90
Location	Top center of main unit
Activates upon	Tank discharge hose disconnected, low pressure in tank, or high temp fault (190° F at hood)

MAINTENANCE ALARM SPECIFICATIONS

Type	Dry Contact
Type of Contacts	Com / NO
Contact Amperage	5 Amps
Location	PLC contacts C0 and Y0
Activates upon	Tank discharge hose disconnected, low pressure in tank, or high temp fault (190° F at hood)

MICRO-SWITCH LAYOUT

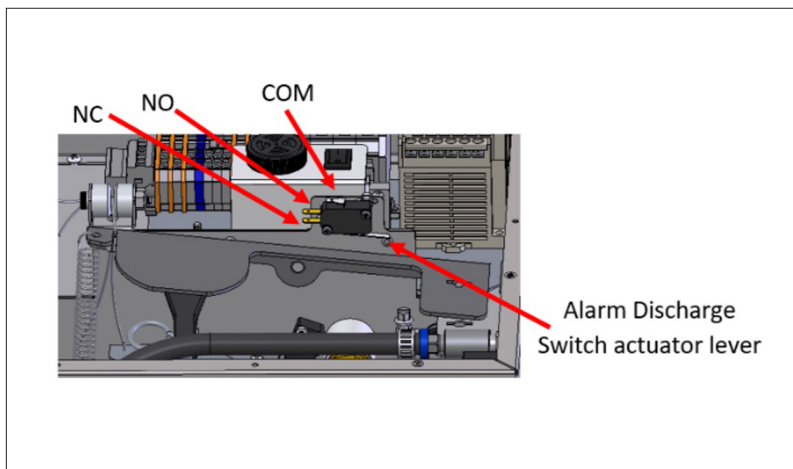

LOCAL ALARM SPECIFICATIONS

Type	Dry Contact
Type of Contacts	Com / NO
Contact Amperage	5 Amps
Location	PLC contacts C1 and Y1
Activates upon	Low pressure in tank, and high temp fault (190° F at hood)

MICRO-SWITCH SPECIFICATIONS

Type	Dry Contact
Type of Contacts	Com / NO / NC
Contact Amperage	15 Amps
Location	Above tank actuation paddle
Activates upon	Mechanical discharge of the tank

SUPPRESSION TANK: -TANK-FC/SA (D1000)

UNIT DIMENSIONS

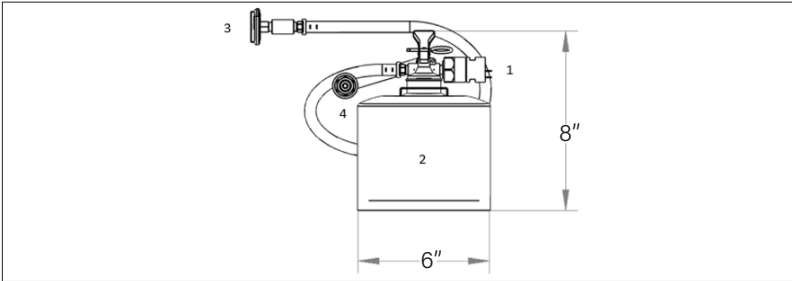

- | | |
|---|---|
| 1 | Tank is Equipped with a Pressure Switch which opens on discharge. |
| 2 | Tank is of Stainless Steel Construction. |
| 3 | Visual Pressure Gauge. |
| 4 | Discharge Hose with Quick Connect fitting attached. |

FC SPECIFICATIONS

Type	Self Contained Fire Suppression System
Compliance	UL-1995
Mounting Configuration	Integral to the hood
Weight	9.4 lbs
Vessel	Stainless Steel
Chemical Type	Amerex 660
Volume	1300 mL
Chemical Weight	2.2 lbs
Pressure (PSI) +-8%	102 PSI
Height	8 in
Width	6 in

NOZZLE PLACEMENT (PRE-INSTALLED IN HOOD)

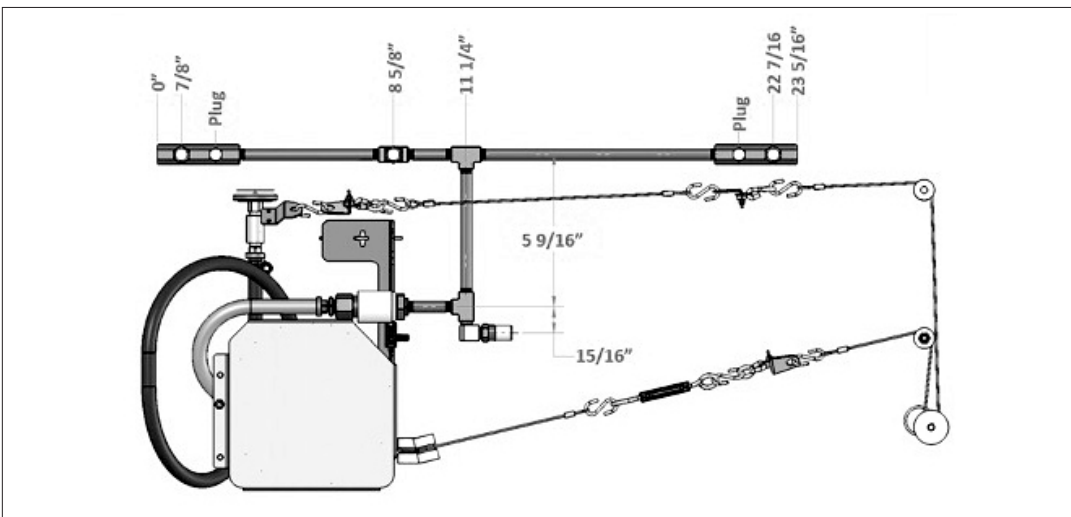

TANK LOCATION

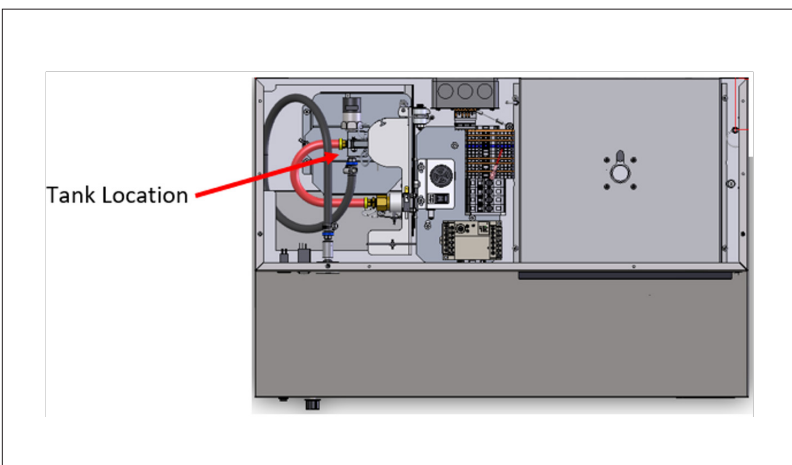

SA SPECIFICATIONS

Type	Self Contained Fire Suppression System
Compliance	UL-1995
Mounting Configuration	Integral to the hood
Weight	9.4 lbs
Vessel	Stainless Steel
Chemical Type	Amerex 660
Volume	1300 mL
Chemical Weight	2.2 lbs
Pressure (PSI) +-8%	Charge to 102 PSI on site
Height	8 in
Width	6 in