

# AIR AND DAMPER CONTROL MODULE: -MACM (D1000)

## UNIT DIMENSIONS

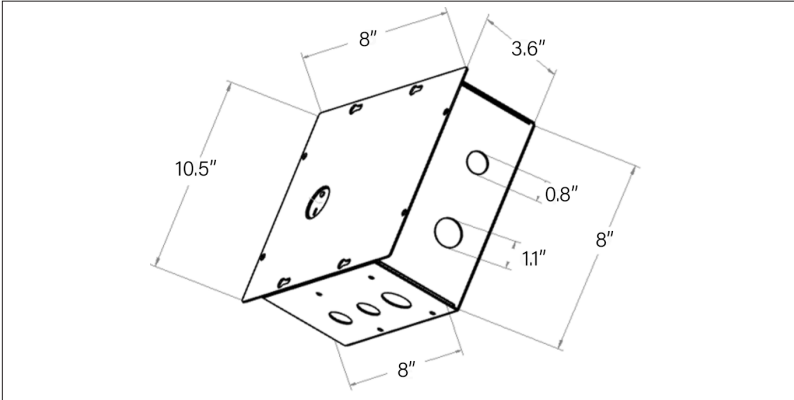

Includes a 15' 16 mm Flexible ENT Conduit with Plenum Cable.

## SPECIFICATIONS

Coil Voltage	120 AC
Phase	1
Frequency	60 Hz
Coil Rating Fuse	0.5 Amps
Fuse type	5 mm x 20 mm Cartridge
Operating Current	0.25 Amps
Fuse	10 Amps
Relay Contact Rating	10 Amps
Operating Current	See Fan Model
Output Volts	See Fan Model
Material Information	
Weight	6.4 lbs
Material	Galvanized
Mounting Type	Surface or Flush Mount
Mounting Height	See Local Codes

## SCHEMATIC

