

DEVICE FLOW CHART

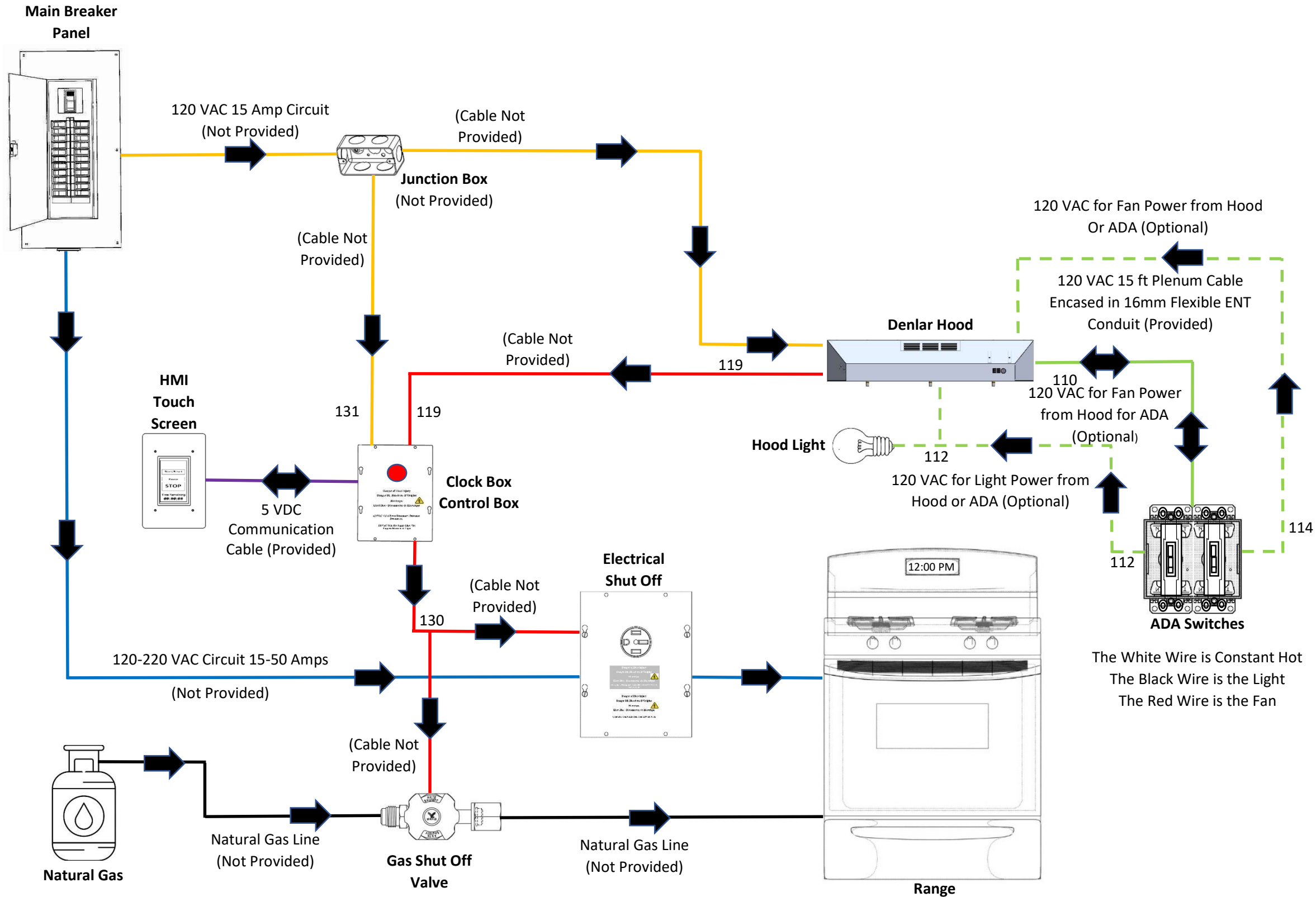

Legend

- The Orange Color Lines represents the Main 120 VAC Power from the Main Breaker Panel to the Hood and Clock Box (Optional).
- The Blue Color Lines represent the Main 220 VAC 50 Amp Circuit for an Electric Range or the 120 VAC for a Gas Range Ignitors and miscellaneous Electrical Components.
- The Black Lines represents the Natural Gas Line.
- The Purple Lines represents the 5VDC Communication Cable for the Clock Box Control Box to the HMI Touch Screen.
- The Red Lines represents the 120 VAC the Hood sends to the Electrical Shut Off, the Gas Shut Off Valve, or the Clock Box (Optional).
- The Green Lines represents the ADA (Optional).
- The Green Dotted Lines represent the signal sent from the ADA to the corresponding components. The physical wires are in the ADA harness, (see Legend #6).

The White Wire is Constant Hot
The Black Wire is the Light
The Red Wire is the Fan

DENLAR
FIRE PROTECTION
PRE-ENGINEERED RANGE HOODS
 Rev. 20200204
 The World's Only Fail-Safe UL300A Hood