

DENLAR

FIRE PROTECTION

PRE-ENGINEERED RANGE HOODS



Designer Series (DS) Models

Installation and User's Manual

Version: 3

MODELS:

DS-30-F

DS-30-D

DS-30-D-IF

DS-30-D-FB0



THIS PAGE IS INTENTIONALLY BLANK

READ AND SAVE THESE INSTRUCTIONS

IMPORTANT SAFETY INFORMATION

Instructions shall be provided with the appliance so that the appliance can be installed, operated, and serviced safely.

Failure to follow the instructions in this manual may result in property damage, personal injury, or death.

These instructions apply to the appliance as supplied and to any approved accessories installed in accordance with this manual.

WARNING

TO REDUCE THE RISK OF FIRE, ELECTRIC SHOCK, OR INJURY TO PERSONS OBSERVE THE FOLLOWING:

1. Use this unit only in the manner intended by the manufacturer. This appliance is intended for indoor installation above residential cooking appliances only. It is not intended for commercial cooking, outdoor use, or installation over solid-fuel burning appliances.
2. This appliance is not intended for use by persons (including children) with reduced physical, sensory or mental capabilities, or lack of experience and knowledge, unless they have been given supervision or instruction concerning use of the appliance by a person responsible for their safety. Children shall be supervised to ensure that they do not play with the appliance.
3. Before servicing or cleaning the unit, place the hood into Maintenance Mode and disconnect it from the power supply.
This prevents the appliance from being powered ON accidentally during service.
Unplug the power cord from the receptacle or switch off the circuit breaker supplying the hood.
When the Maintenance disconnect cannot be locked, securely fasten a prominent warning device (such as a tag) to the Maintenance panel to alert others that the appliance is being serviced.
4. Installation work and electrical wiring must be done by a qualified person(s) in accordance with applicable codes and standards, including fire-rated construction codes and standards.
5. This appliance must be connected to a properly grounded outlet. Do not remove the grounding prong from the plug, use an adapter, or connect to an ungrounded outlet. To provide protection against electric shock, connect only to a properly grounded, 3-prong receptacle.
6. Route the power cord so that it is not exposed

to hot surfaces, sharp edges, or pinch points. Do not allow the cord to contact the cooktop or oven door. Do not run the cord under carpeting or where it may be stepped on or tripped over. Do not pull, twist, or place tension on the power cord.

7. If the supply cord is damaged, it must be replaced by the manufacturer, its service agent, or similarly qualified persons in order to avoid a hazard. Do not use the appliance if the supply cord or plug is damaged.
8. Sufficient air is needed for proper combustion and exhausting of gases through the flue (chimney) of fuel burning equipment to prevent back drafting. Follow the HVAC equipment manufacturer's guidelines and safety standards such as those published by the National Fire Protection Association (NFPA) and the American Society of Heating, Refrigeration and Air Conditioning Engineers (ASHRAE), and the local code authorities.
9. When cutting or drilling into wall or ceilings do not damage electrical wiring and other hidden utilities.
10. To reduce the risk of fire or electric shock, do not use this range hood with an additional speed control device, unless provided by Denlar Fire Protection.
11. Ducted fans must always be vented outdoors.
12. To reduce the risk of fire, use only metal ductwork, or follow local code.
13. Use with approved wiring only.
14. This appliance is not intended to support additional weight. Do not hang objects from the hood, the filters, or any part of the appliance, and do not place items on top of the hood.

TO REDUCE THE RISK OF A RANGE TOP GREASE FIRE:

1. Never leave cooking unattended. Overheated food, oil, or grease can ignite and cause a fire.
2. Never leave surface units unattended at high settings. Boil-overs cause smoking and greasy spillovers that may ignite. Heat oils slowly on low or medium settings.
3. Do not cook with excessive open flame or allow flame heights that extend into the hood. Excessive flame or flare-ups may damage the hood, ignite grease, or activate the fire-suppression system.
4. Always turn the fan ON when cooking at high heat or when cooking foods that may flame.
5. Clean ventilating fans, hood surfaces, ductwork, and filters frequently. Grease should not be allowed to accumulate on the hood, fan, duct, or

1. filter surfaces.
2. A grease-laden hood or blocked duct can ignite and cause a fire.
3. Use proper pan size. Always use cookware appropriate for the size of the surface element.

CAUTION

TO REDUCE THE RISK OF INJURY TO PERSONS IN THE EVENT OF RANGE TOP GREASE FIRE OBSERVE THE FOLLOWING:

1. SMOTHER FLAMES with a close-fitting lid, cookie sheet, or metal tray; then turn off the burner. BE CAREFUL TO PREVENT BURNS. If the flames do not go out immediately, EVACUATE AND CALL THE FIRE DEPARTMENT.
2. NEVER PICK UP A FLAMING PAN – You may be burned.
3. DO NOT USE WATER, including wet dishcloths or towels – violent steam explosion will result.
4. Use an extinguisher ONLY if:
 - A. You know you have a Class k extinguisher and you already know how to operate it.
 - B. The fire is small and contained in the area where it started.
 - C. The fire department is being called.
 - D. You can fight the fire with your back to an exit.

*Based on "Kitchen Fire Safety Tips published by NFPA

To Reduce General Risk

1. For general ventilating use only. Do not exhaust hazardous or explosive materials and vapors.
2. To avoid motor bearing damage and noisy and/or unbalanced impellers, keep drywall debris, construction dust, etc. away from hood.
3. For best capture of cooking impurities and performance of fire extinguisher, your range hood should be mounted so that the bottom of the hood is 18-26" for DS models above the cooking surface.
4. Please read Data sheets provided by Denlar Fire Protection for further information and requirements.
5. Wear safety glasses.

DISCLAIMER:

DENLAR Fire Protection shall not be liable for errors contained in this Manual or for incidental, consequential damages in connection with the furnishing, performance or use of this information. DENLAR Fire Protection makes no warranty of any kind with regard to this information, including, but not limited to the implied warranties of merchantability and fitness for a particular purpose.

TABLE OF CONTENTS

READ AND SAVE THESE INSTRUCTIONS	3
HOOD SPECIFICATIONS	6
HOOD LAYOUT	7
ELEVATION LAYOUT	8
HOOD MODELS AND ACCESSORIES	9
MOUNTING LAYOUT	10
POWER CONNECTIONS	12
OPERATING THE DESIGNER SERIES HOOD	14
MANUAL PULL STATION INSTALLATION (MPK)	15
ALARM CONNECTIONS	16
RANGE ELEMENT DISCONNECT INSTALLATION.....	17
RANGE ELEMENT DISCONNECT SCHEMATIC.....	18
HANDICAP ACCESSIBLE CONTROL (ADA).....	21
TANK REMOVAL.....	23
DESIGNER SERIES TESTING	24
DESIGNER SERVICE	26
DESIGNER SERIES SCHEMATIC.....	27
DESIGNER SERIES DEVICE FLOW CHART	28

HOOD SPECIFICATIONS

	Hood Specifications							
	Mounting Config.	Length (In.) (B)	Height (In.) (C)	Height (In.) (C)	Weight (lbs.)	Material	Mounting Height (In.)	Compliance
DS-30-F	Wall	30	19.25	7	33.25	Stainless Steel or Powder coat	Low: 18 High: 26	UL 300A UL507
DS-30-D					29.25			
DS-30-D-IF					29.25			

	Electrical Specifications							
	Voltage (VAC)	Phase	Breaker (Amp)	Frequency (Hz.)	Internal Fuse (Amp)	Continuous Operating Current (Amp)	Fan Operating Current (Amp)	Output Operating Current (Amp)
DS-30-F	120	1	15	60	2	0.61	Low: 0.41 High: 0.57-1.32	0.25
DS-30-D					3.15	Low: 1.2		
DS-30-D-IF					3.15	High: 2.15		

	Fan Specifications							
	Location	Voltage (VAC)	Phase	Frequency (Hz.)	Internal Fuse (AMP)	Continuous Operating Current (Amp)	Speeds	Weight (lbs.)
DS-30-F	Integral to Hood	120	1	60	2	Low: 0.41 High: 0.57	Off / Low / High	4
DS-30-D					3.15	1.32		
DS-30-D-IF	External Inline				3.15	1.32	Off / High	8.5

	Fan Specifications					
	CFM (Low-High)	Pressure (In. Water)	DBA (Low-High)	Hood Outlet (In.)	Duct (In.)	Fan Outlet (In.)
DS-30-F	30-40 (Two Speed)	0.08	57-66	9 x 2.5	N/A	N/A
DS-30-D				7	7	
DS-30-D-IF	330 (Single Speed)	0.94	60	7	7 - 8	8

	Fire Suppression Specifications								
	Type	Media type	Volume (ml.)	Weight (lbs.)	Pressure (psi.) +8%	Tank Material	Dia (In.)	Height (In.)	Fire Detectors
DS-30-F	Self Contained	Amerex 660	900	1.8	102	Stainless Steel	3	15	Glass (250 Deg F)
DS-30-D									
DS-30 D-IF									

	Fire Suppression Specifications		
	Qty.	Nozzles	Qty.
DS-30-F	2	60 Deg. Conical	2
DS-30-D			
DS-30 D-IF			

	Coil Ratings						Material Information			
	Coil Voltage (AC)	Phase	Frequency (Hz.)	Fuse (AMPS)	Fuse Type	Operating Current (AMPS)	Weight (Lbs.)	Material	Mounting Configuration	Mounting Height (IN.)
DS30-D-FBO	120	1	60	0.5	5X20MM Cartridge	0.25	6.4	Plastic	Surface Mount Or Flush Mount	See Local Codes

Note: The range hood must be installed 18-26" above the cooking surface.

HOOD LAYOUT

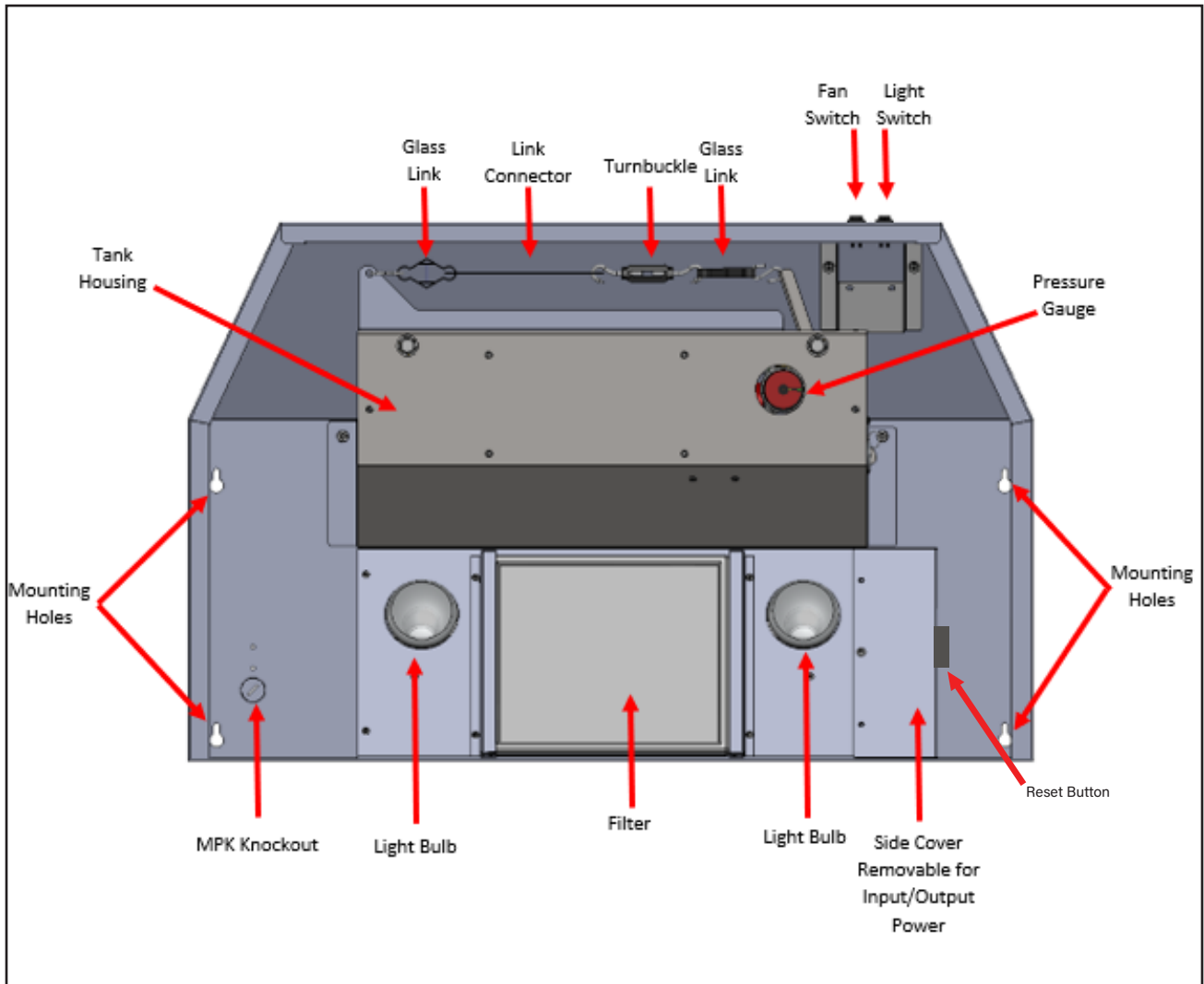

ELEVATION LAYOUT

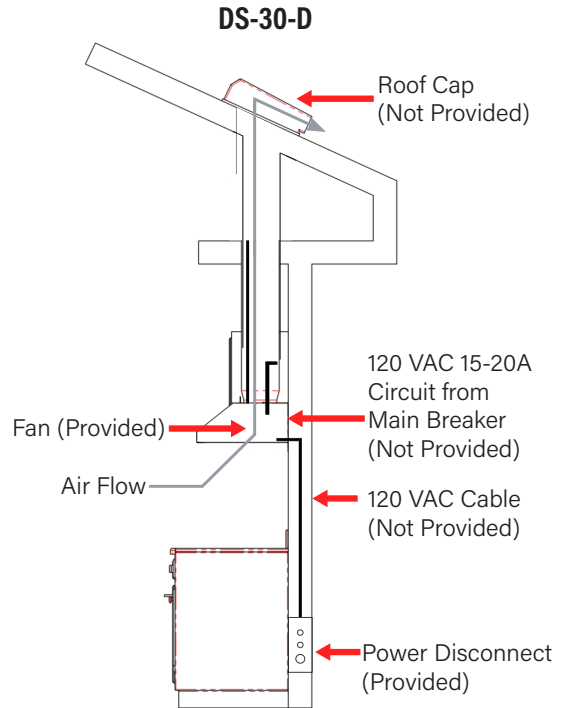
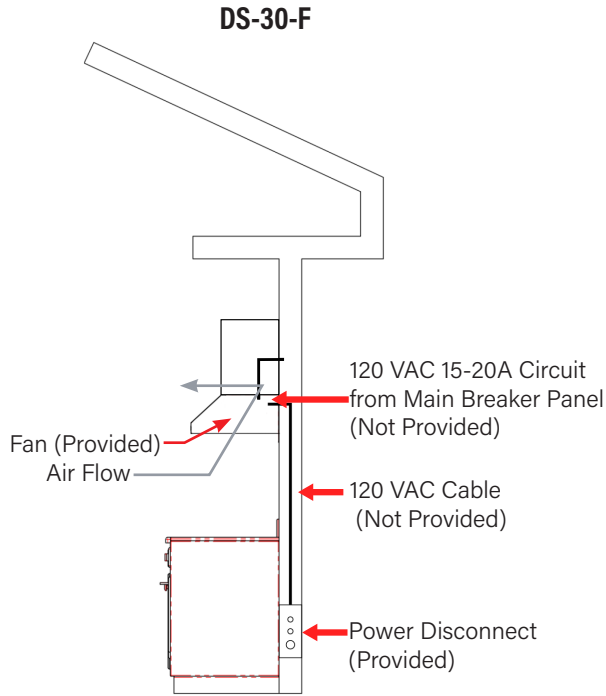

NOTE: For the DS-30-D it is recommended to run the duct work via the shortest route possible. This includes if possible, to duct out to an exterior wall. If a long duct work run is required, then an inline fan is recommended.

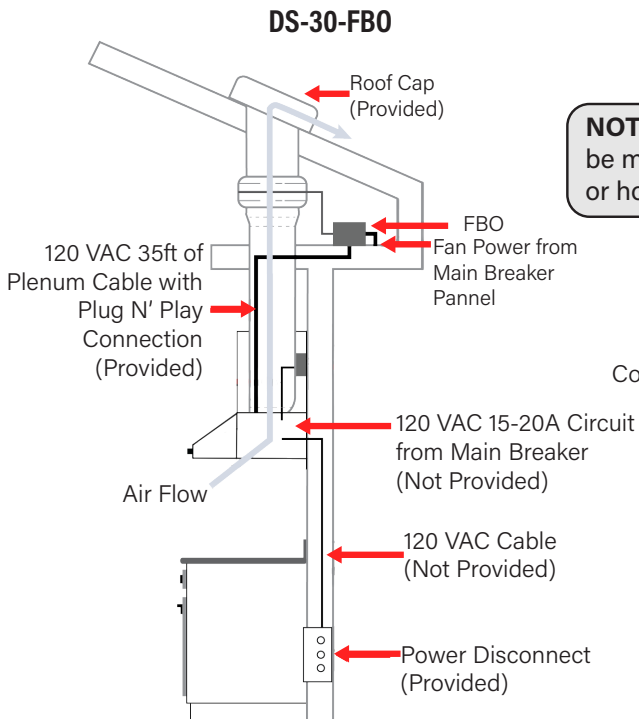

NOTE: Inline fan can be mounted vertically or horizontally.

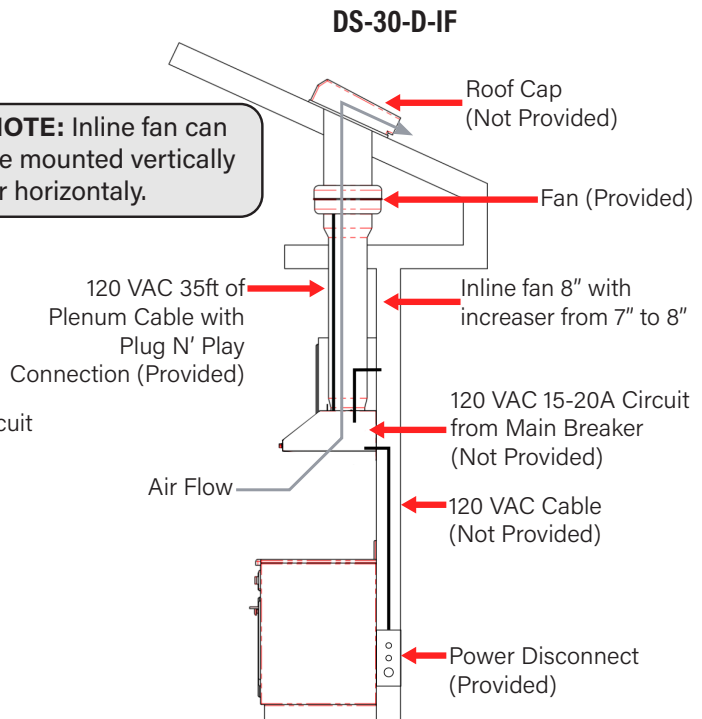

HOOD MODELS AND ACCESSORIES

The DS30 available in with multiple venting and fan configurations.

Verify the hood model designation and vent configuration before planning ducting, electrical connections, and accessory installation.

The Hood Model DS30 is approved for 30" residential ranges.

Vent Configuration and Fan Designations

Hood Model Designation	Vent Type & Fan Configuration
DS30-F	Front vented, recirculating design with integral fan
DS30-D	Top vented, vertical duct connection with integral fan
DS30-D-IF	Top vented, vertical duct connection with external 8" inline fan, supplied with 35 ft interconnecting cable
DS30-D-FBO	Top vented, vertical duct connection in Fan-By-Others (FBO) control module; fan supplied by others (see data sheet for restrictions)

Available Accessories and Options

Accessory / Option	Function	Electrical Rating
DS-MPK	Manual Pull Kit – enables manual activation of the fire suppression system via pull station and cable assembly.	N/A
DS-ADA	Accessible control kit providing remote fan and light control in accordance with accessibility requirements.	120 VAC, 15 A
CLBX	ClockBox™ time-out controller providing password-protected range operation control.	120 VAC, 15 A
DS-E-220 14-50	Electric range disconnect accessory.	120/240 VAC, 50 A (NEMA 14-50)
DS-E-120 5-15	Electric range disconnect accessory.	120 VAC, 15 A (NEMA5-15)
DS-E-120 5-20	Electric range disconnect accessory.	120 VAC, 20 A (NEMA5-20)
DS-E-220 10-50	Electric range disconnect accessory.	120/240 VAC, 50 A (NEMA 10-50)
DS-E-220 6-20	Electric range disconnect accessory.	240 VAC, 20 A (NEMA6-20)
DS -G	Gas range disconnect accessory	N/A
DS -DED-120 5-20	Dual Element Disconnect for use with Dual Fuel Stoves	120 VAC, 20 A (NEMA5-20)
DS -DED-220 14-50	Dual Element Disconnect for use with Dual Fuel Stoves	120/240 VAC, 50 A (NEMA 14-50)
DS -DRD-120 5-15	Dual receptacle disconnect accessory for range power.	Two outlets 120 VAC, 15 A (NEMA 5-15)
DS -DRD-120-5-20	Dual receptacle disconnect accessory for range power.	Two outlets 120 VAC, 20 A (NEMA 5-20)
DS -DRD-120-6-20	Dual receptacle disconnect accessory for range power.	Two outlets 240 VAC, 20 A (NEMA 6-20)

Accessory Instructions:

Some accessories listed above are supplied with separate instructions. Where applicable, follow the accessory-specific instructions provided with the accessory in addition to the instructions contained in this manual.

MOUNTING LAYOUT

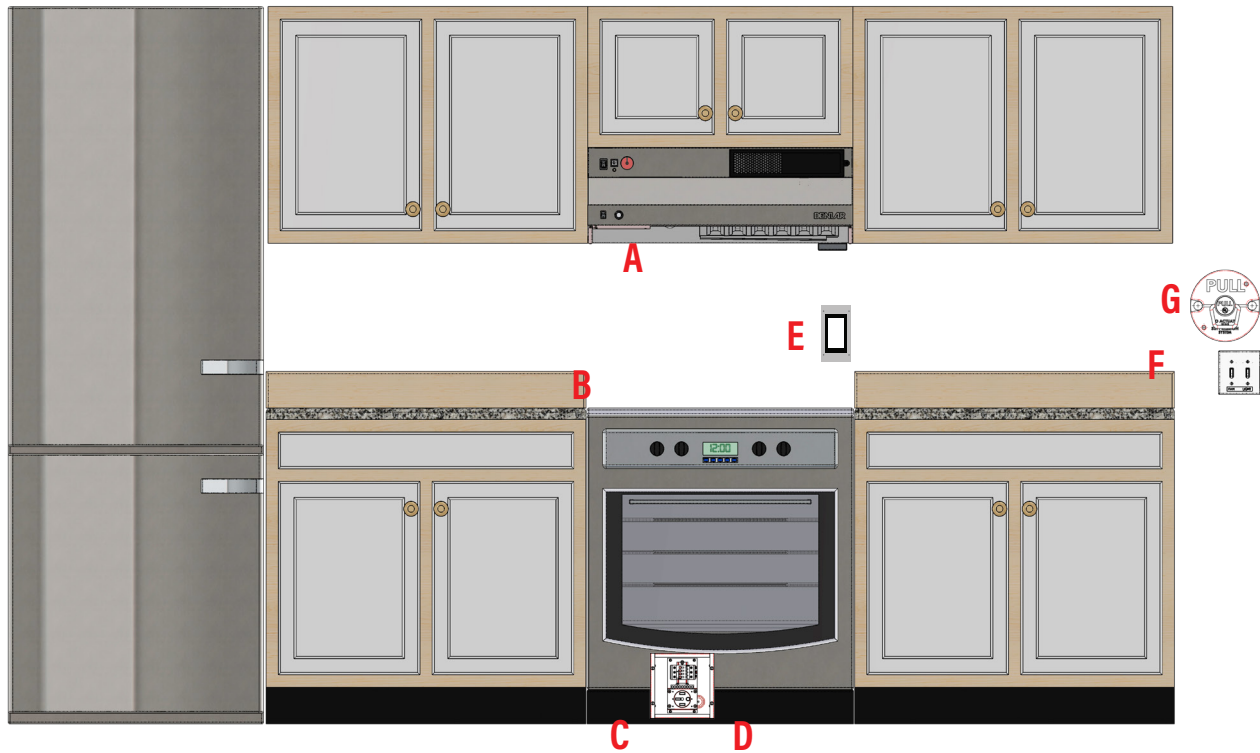

- A. DENLAR Designer Series Hood (DS-30)
- B. Range (for reference purposes (Gas, Electric or Dual Element))
- C. Electric Power disconnect (shown)
- D. Gas Power Disconnect (not shown)
- E. The ClockBox range element lockout system (CLBX option) The Touchscreen (E) is shown, the control module is not shown.
- F. Handicap Accessible Control Box (ADA option)
- G. Manual Pull Station (MPK option)

WARNING: Hoods are only approved for use over a like sized residential range, stove, or cooktop.

MOUNTING LAYOUT

The Hood has two options for mounting. There are four mounting holes in the top and rear of the unit. If a cabinet is installed above the Hood with top discharge or an inline fan, then a 7" hole is required in the cabinet. If a Hood

has a Manual Pull Station (MPK), then a 0.85" diameter hole is needed. See Cabinet Bottom View for the placement of the holes required.

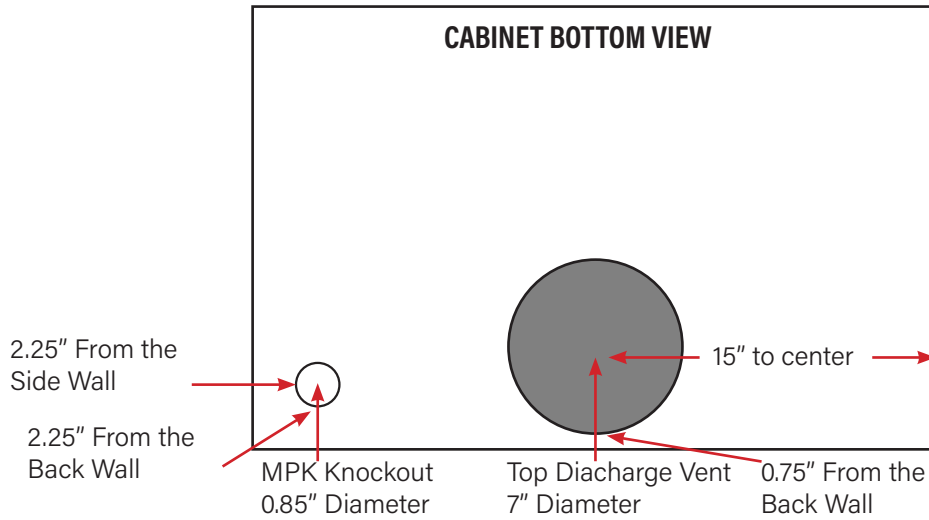

There are four knockouts (KO) for the input and output power. It is recommended to use the two KO's on the right side of the hood, next to the side cover. This allows the wiring to be installed in a more efficient manner.

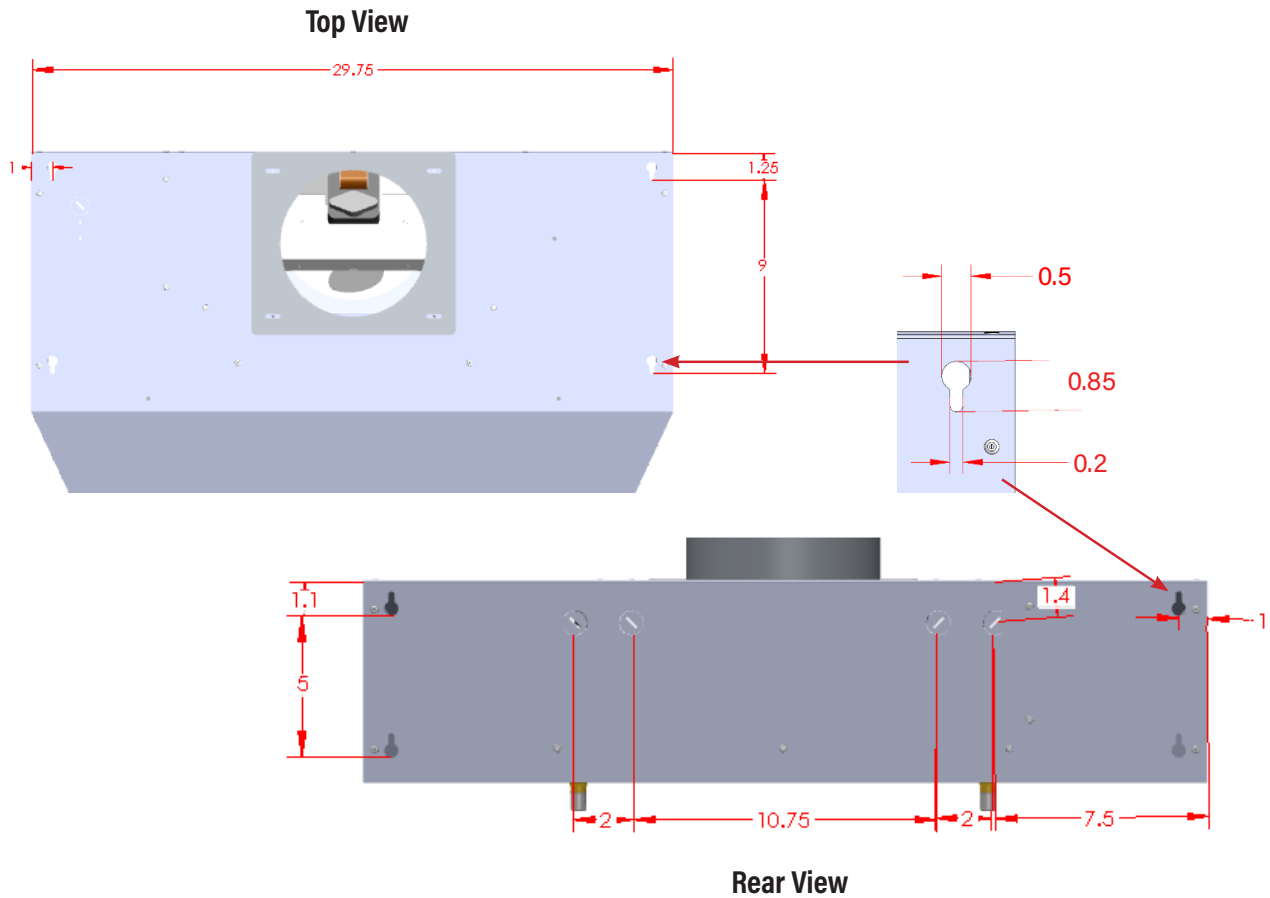

POWER CONNECTIONS

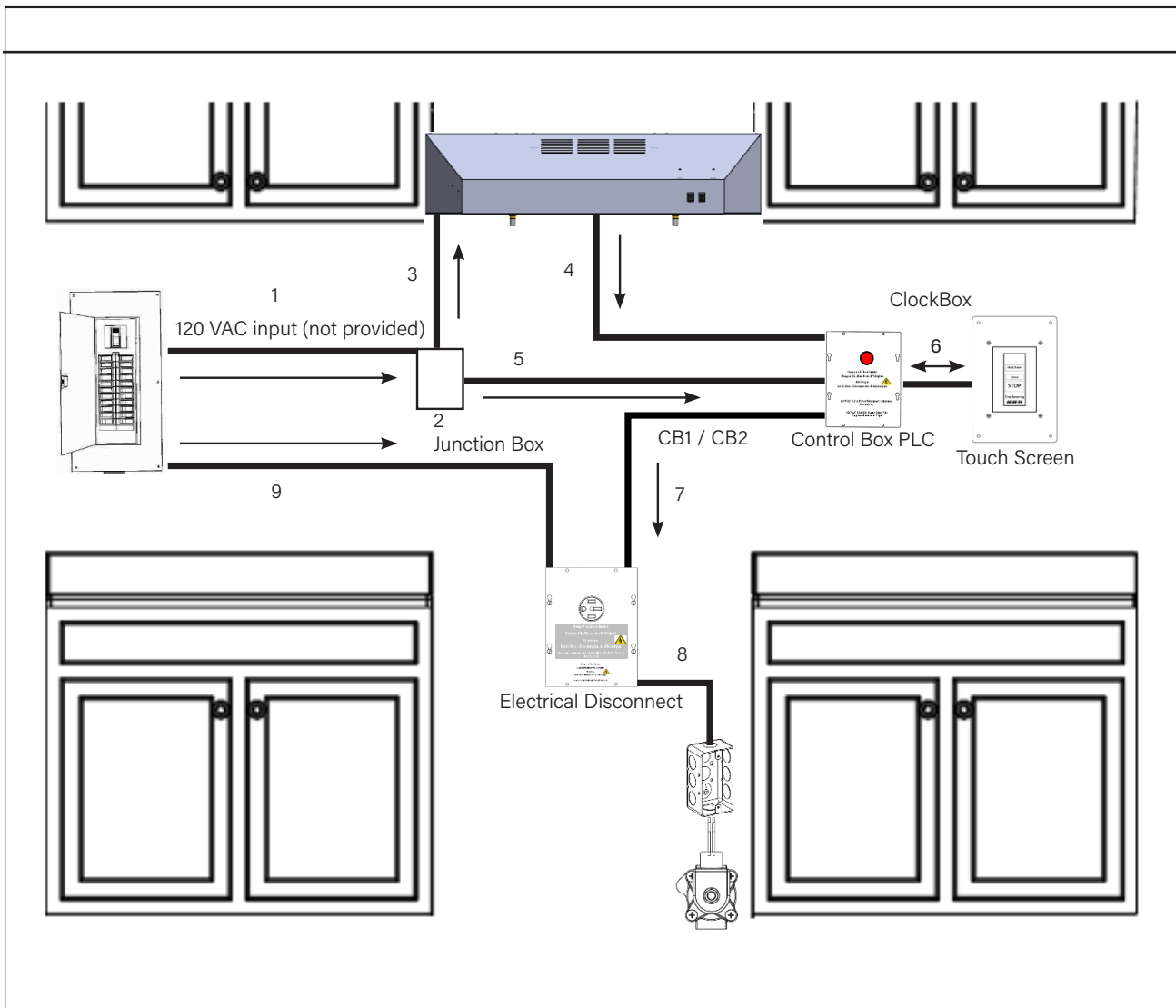

1. 120 VAC Input (not provided). The DS hood is hard wired into the electrical supply. A suitable disconnect must be incorporated into the fixed wiring. The installation must comply with all national and local codes.
 - a. 120 VAC / 15 Amp circuit (provided by installer)
 - ii. If a ClockBox is not used, connect the wire directly to the Hood, skip to Step 3.
2. Junction Box (not provided)
 - a. Run the 120 VAC Input to the Junction Box.
 - b. Run a 120 VAC Input Power Cable (3, not provided), from the Hood to the Junction Box.
 - c. Run a new cable (5, not provided) from the Junction Box to the ClockBox Control Box (if applicable).
 - d. Wire Nut the Hot leads from the three wires (1, 3, 5) together.
 - e. Wire Nut the Neutral leads from the three wires (1, 3, 5) together.
 - f. Connect the grounds accordingly (1, 3, 5).

POWER CONNECTIONS

3. 120 VAC Input Power Cable (not provided).

- a. Remove the side cover of the Hood, there is a six-position connector in the compartment. The wire combination is Brown, White, Green, Green, White, and Blue. The mating connector is attached to the plug. The connector is push-to-connect. The wires are required to be solid or terminated with ferrules.
 - ii. The Line connects to the Installer Side connector in the 120 VAC position.
 - iii. The Neutral connects to the Installer Side connector in the Neutral position.
 - iv. The Ground connects to the Installer Side connector in the Ground position.

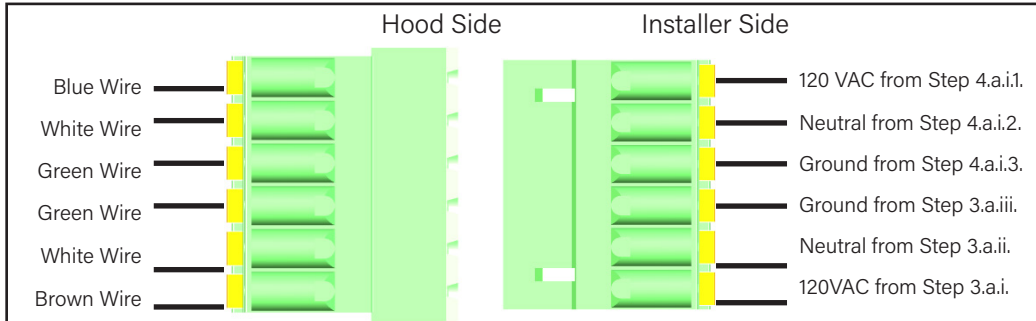

4. 120 VAC Output Cable from the Hood (not provided)
 - a. Hood Side
 - b. Other Side
 - iii. If a ClockBox is not used connect the wire directly to the coil of the power disconnect (Step 7).
 - d. If using a ClockBox, then proceed with the next step.
 - iv. Connect the 120 VAC Output Cable to the eight (8).
 - v. The Line connects to position one (P1).
 - vi. The Neutral connects to position two (P2).
 - vii. The Ground connects to position three (P3).
5. Cable (not provided) to provide 120 VAC from the Main Breaker Panel to the ClockBox (if applicable).
 - a. Connect the 120 VAC Output Cable to the Installer Side of eight (8) position Power Plug in the Clock-Box Control Box.
 - ii. The Line connects to position four (P4).
 - iii. Connect the Neutral to position eight (P8).
 - iv. The Ground connects to the Ground Bar.

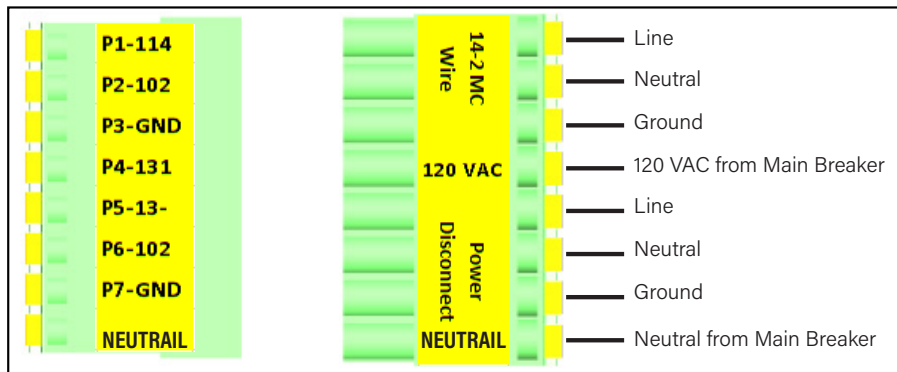

6. 5 VDC Input / Output Communication cable encased in 16 mm ENT Flexible Conduit (provided).
 - a. 25 Ft in length
 - b. One communication
 - c. Connects between the ClockBox PLC and Touch Screen
7. Output Power Disconnect Cable (not provided)
 - a. Connect the cable to the other end to the coil of the Power Source Disconnect (DS-E, DS-G, DS-DRD, or DS-DED).
8. Jumper cable for the DS-DED (if applicable, not provided)
9. Supply Line 120-220 VAC from the Main Breaker Panel to the DS-E for range (not provided).

OPERATING THE DESIGNER SERIES HOOD

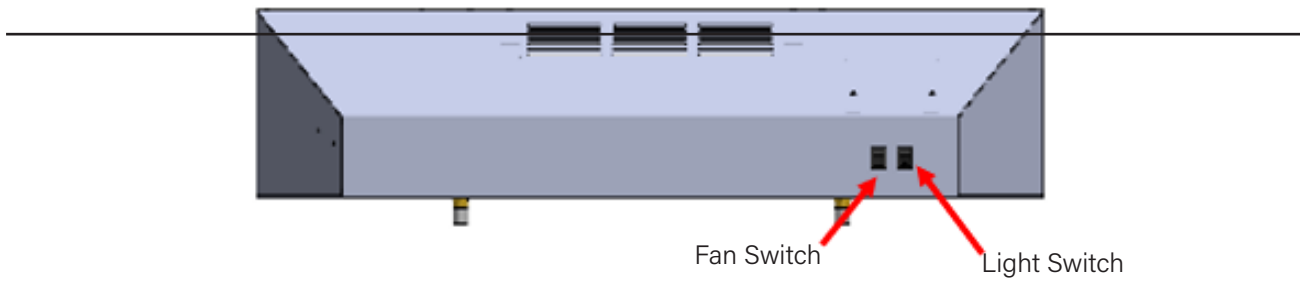

Fan and Light Operations

The Designer Series Hood is equipped with two switches. The switch on the right is for the two lights in the Hood. The light switch is a two-position switch marked "O", and "I". The "O" is OFF and "I" turns the lights ON. The switch on the left is for the fan motor. This switch is a three-position rocker switch. The positions are marked "O", "I", and "II". The "O" marking keeps the fan motor off. The "I" marking sets the fan motor to low speed. The "II" marking sets the fan motor to high speed. If the Hood is equipped with an inline external fan motor (DS-30-D-IF) then the Fan Switch is an ON or OFF switch, there is no speed control.

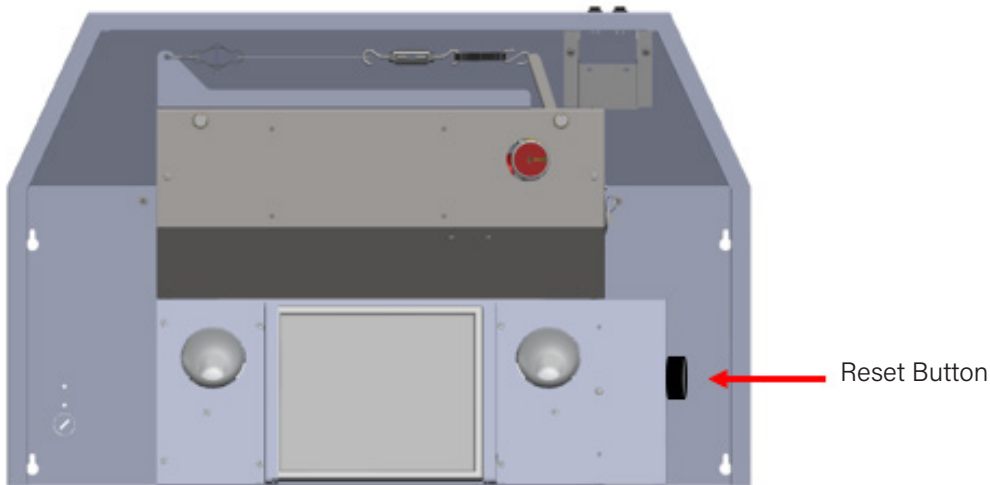

Reset Button

There is a Reset Button located on the Hood, this is to ensure someone is available to light the igniters if they are not automatic and prevent an accident. If the Hood loses power, the Reset Button is needed to be pressed again to open the valve or close the coil of the electrical disconnect. The Reset Button is a black round push button located on the side cover of the Hood.

After a Discharge

If the Hood discharges, the microswitch powering the power disconnect changes states and shuts off power to the power disconnect. An audible buzzer will sound. To reset the system, a new charged tank assembly will need to be installed.

NOTE: Tanks cannot be recharged in the field.

MANUAL PULL STATION INSTALLATION (MPK)

STEP 1: INSTALLING CONDUIT



Pull Box (X1)



Pull Face (x1)



Elbow Pulley (x3)



Wire Rope Cable crimped with Sleeve and Swivel Hook (25ft)

- Mount the Pull Box in an appropriate location according to local building codes.
- The MPK is supplied with 25ft of wire rope cable and three Elbow Pulleys. If the site requires more than 25ft of Wire Rope or more than three Elbow Pulleys, then it is required to have approval of the local authority.
- Install ½" conduit (not provided) between the unit and the pull box, using the pulleys as needed.
- Pull the Wire Rope Cable through the conduit and allow 8-12" of slack to be left at the Pull Box.

Be sure to abide by all local building and fire codes when installing the conduit.

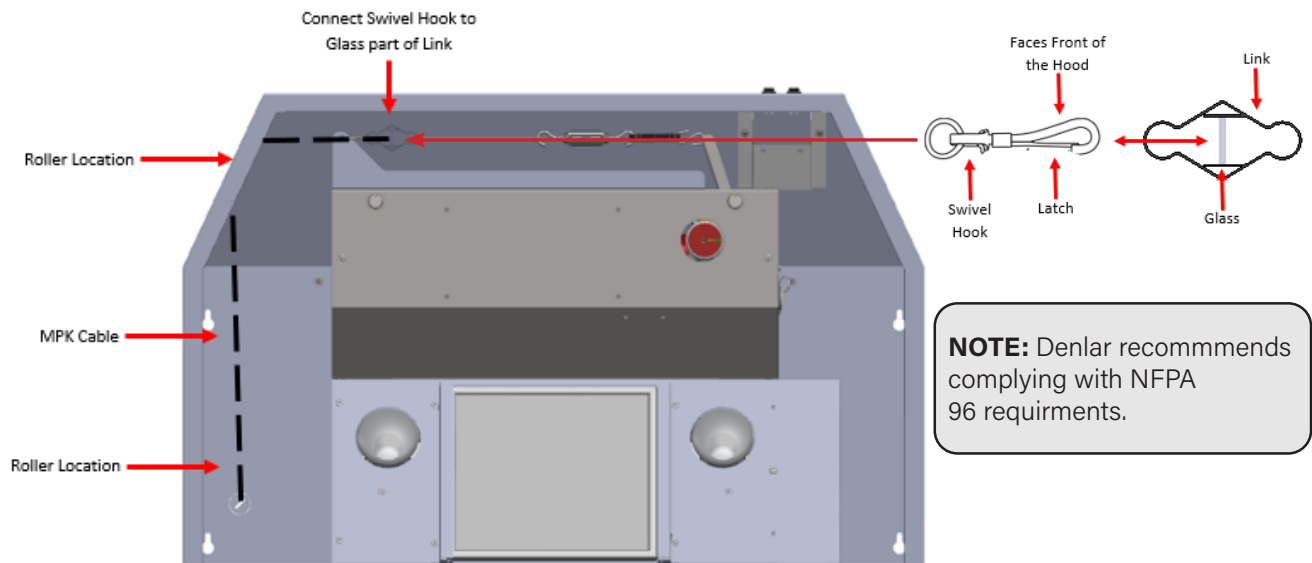

STEP 2: Connecting to the Hood

Run the Wire Rope Cable into the Hood and through the two rollers. Connect the Swivel Hook to the Glass part of the first link. Call out position of hook.

STEP 3: INSTALL WIRE ROPE CABLE TO PULL FACE

- Ensure the wire rope cable is securely crimped to withstand at least 40 lbs. of pull force.
- Maintain 8-12" of slack of slack in the line on the pull face end.
- Remove the MPK handle by loosening the set screw in one of the studs and sliding the red Break-Rod out.
- Insert the Wire Rope through the Compression Fitting, then through the back of the Pull Tab, and then through the Compression Fitting. Crimp the Compression Fitting.
- Attach the pull face to the pull box, collecting the slack into the pull box.

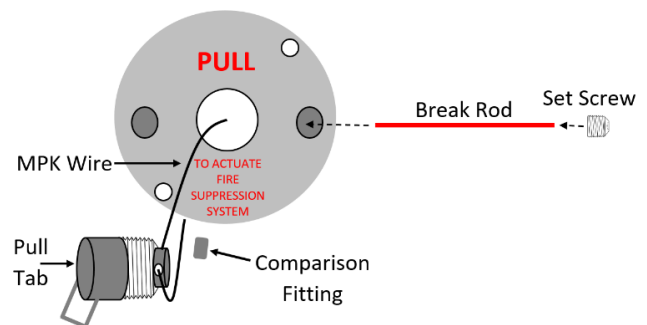

ALARM CONNECTIONS

The Designer Series Hood offers a set of Normally Open (NO) or Normally Closed (NC) Contacts to connect to an alarm panel. To access the connection, remove the side cover, there are three red wires inserted into a Four-Position Connector, this mating connector is plugged into the Four-Position Connector. The terminals are push-to-connect; solid wires or wires with a ferrule are required. The three red wires are numbered 116, 118, and 125. Wire 116 is the Common (COM), wire 118 is the NC contact, and wire 125 is the NO contact. When the Hood is in Normal Operating Mode (NOC) then the microswitch for the contacts is engaged and its state are changed. In NOC, wire 118 is the NO contact and wire 125 is the NC contact. Upon Discharge, wire 118 is the NC contact and wire 125 is the NO contact.

Four-Position Connector

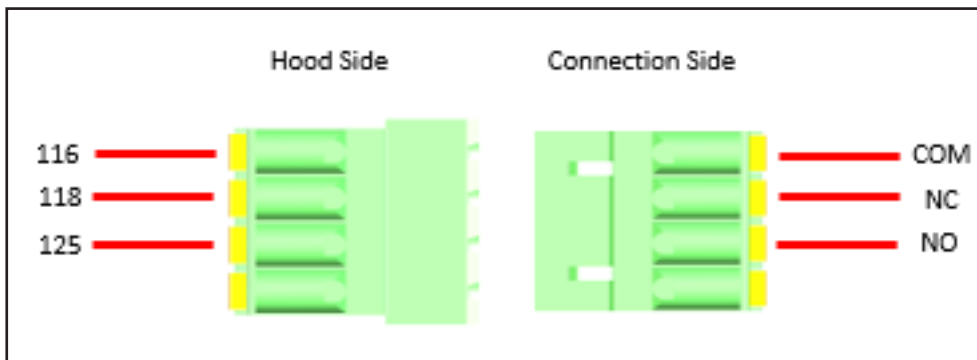

In Normal Operation Mode (NOC) the NO and NC are switched.

RANGE ELEMENT DISCONNECT INSTALLATION

DS-G Installation

Gas Solenoid Disconnect

1. Secure the gas line input and output to the DS-G. The fittings are $\frac{3}{8}$ " NPT. Make note of the direction of the flow, there is an arrow on the bottom of the DS-G.

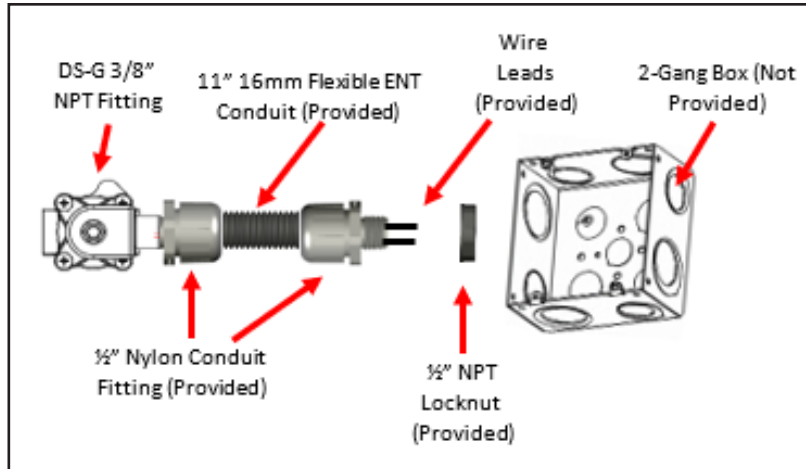

2. The DS-G has an 11" length of 16mm Flexible ENT Conduit encasing a supply line cable attached with a two wire leads at the end. Install the ENT Conduit to a 2-Gang Box (not provided).
3. Run the 120 VAC Output from the Hood (cable not provided), to the 2-Gang Box.
4. Connect the wire leads from the 120 VAC Output to the wire leads of the DS-G. Secure the ground to the 2-Gang Box.
5. Install the cover for the 2-Gang Box.

NOTE: The Coil voltage cannot be used to power the electronics in the range (clock, igniters, etc.). A DS-DED is components of the range need to be powered. Doing this, voids the warranty and ETL listing of the Hood. In addition to blowing the fuse.

DS-E Installation

Electrical Contactor Disconnect

1. Install the DS-E in the drywall (refer to the specification sheets for the dimensions). Be sure to note the $1\frac{1}{4}$ " overhang on both sides of the face plate. The cutout opening should be about $8-\frac{3}{8}$ ". The electrical disconnect has been designed to fit a standard 2" x 4" framed wall.
2. Run the 120 VAC Output (cable not provided) from the Hood, to the power disconnect location. Connect the wires from the coil of the contactor to the wire leads of the 120 VAC Output coming from the Hood. Attach the ground to the ground bar.
3. Run 120 VAC 15 – 20 Amps or 220 VAC 20 – 50 Amps based on the site requirements, from Main Breaker Panel (Not Provided) to the contactor. This will provide power to the receptacle.
4. Secure the face plate to the electrical disconnect.

RANGE ELEMENT DISCONNECT SCHEMATIC

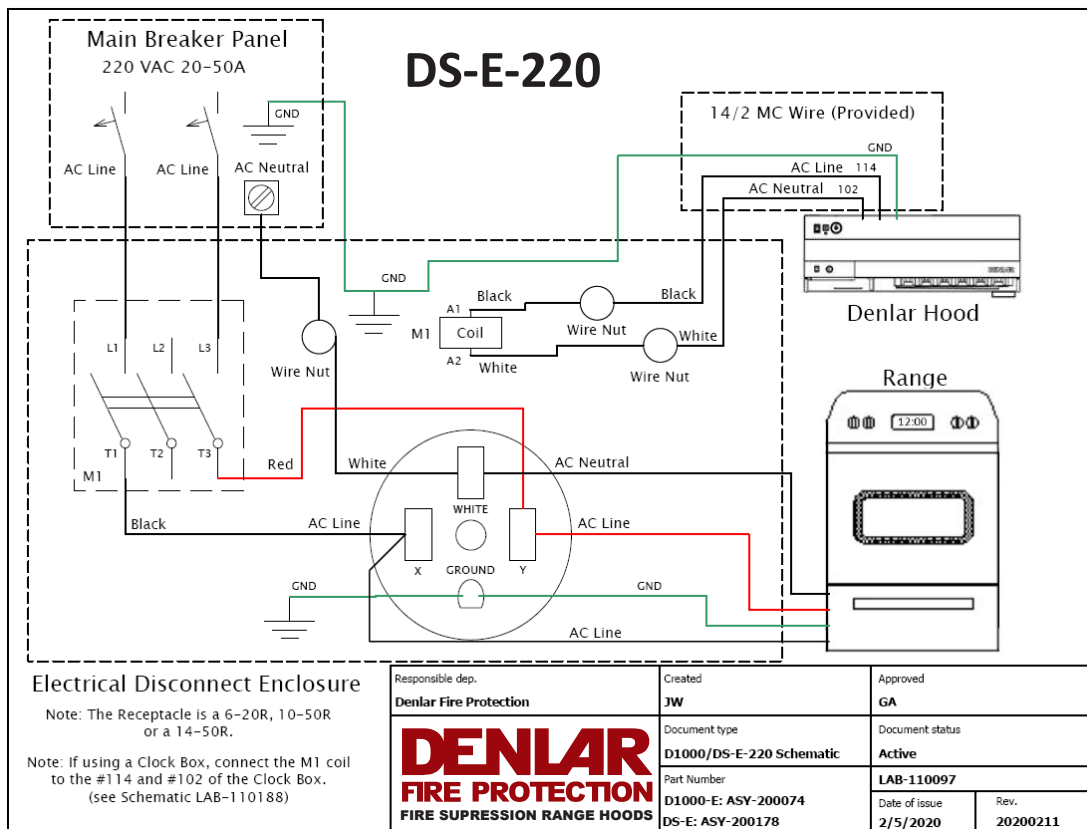
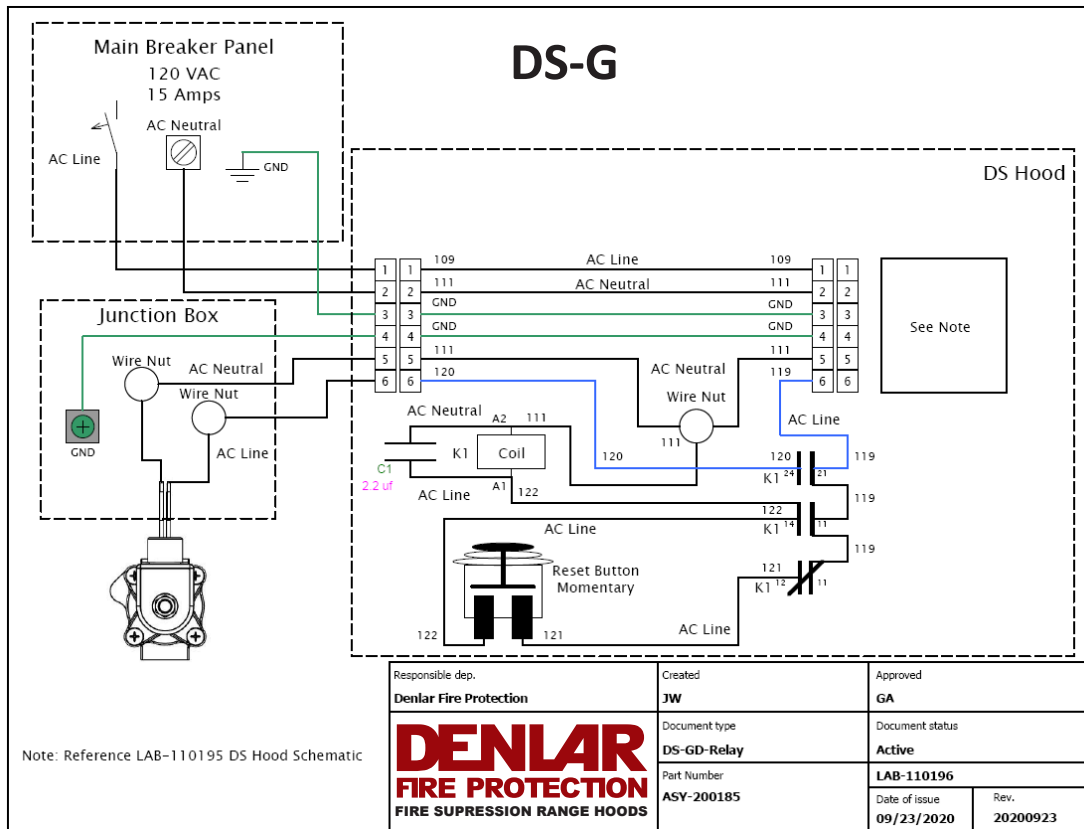

RANGE ELEMENT DISCONNECT SCHEMATIC

DS-DRD-120/220

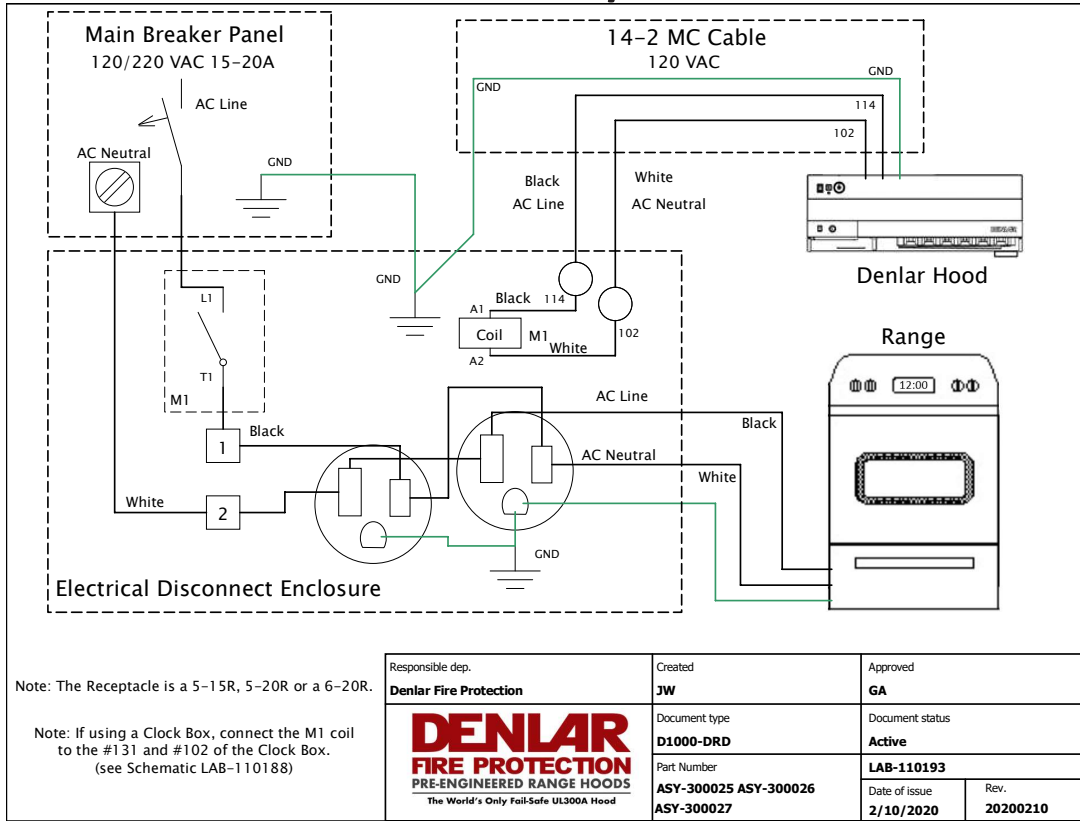

DS-FBO

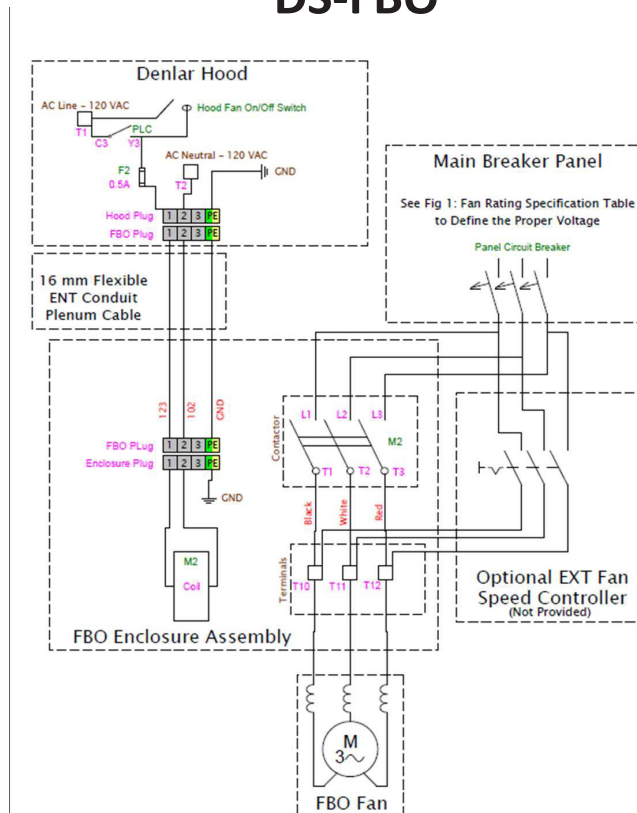

RANGE ELEMENT DISCONNECT SCHEMATIC

DS-E-120

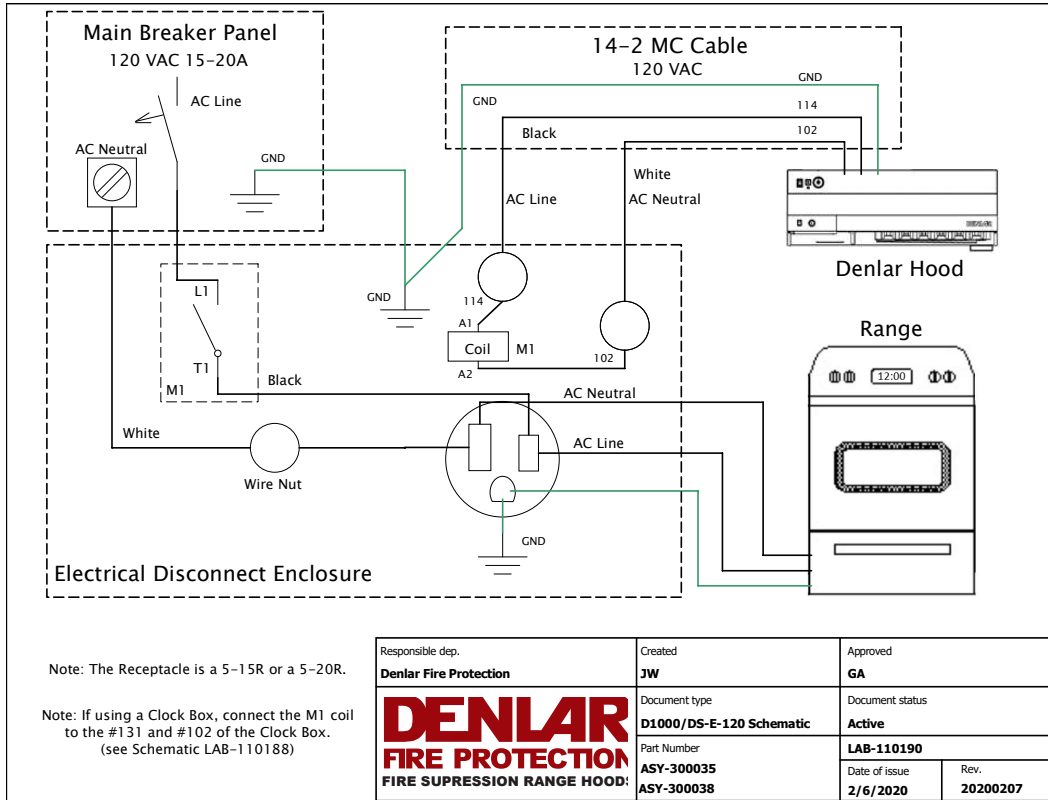

DS-DED-120/220

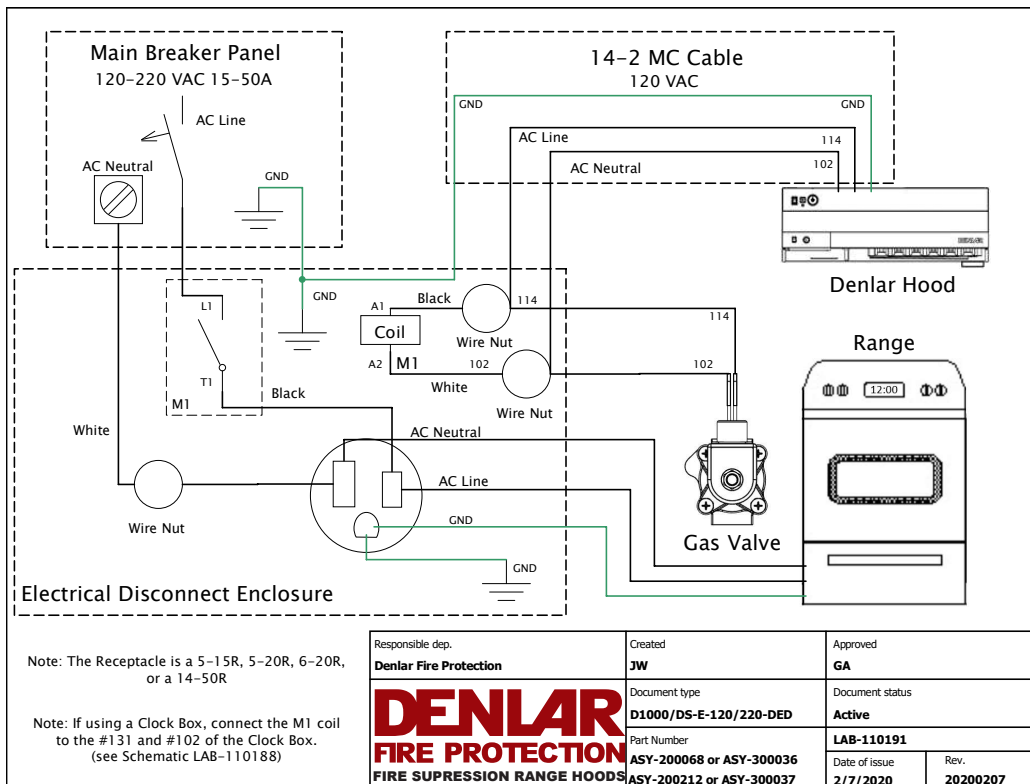

HANDICAP ACCESSIBLE CONTROL (ADA)

COMPONENTS

- ADA Wire Harness Assembly
 - (2) Toggle Switches (white)
 - (1) Metal 2-Gang Enclosure
 - (15 ft) Plenum Cable Encased in 16mm ENT Flexible Conduit
 - (1) Eight-Position Male Connector (Plug-N-Play)
 - (1) 2-Gang White Switch Cover
 - (2) Mounting Brackets

PREPARATION

Turn OFF the supply line 110-120 VAC power (at the panel) to the Hood. Remove the ADA Wire Harness Assembly from the packing.



INSTALLATION

1. Remove the two switches from the Metal 2-Gang Enclosure.
2. Mount the Metal 2-Gang Enclosure to the desired wall location using the mounting brackets in accordance with local building codes and electrical codes.
3. Install the two switches back to the Metal 2-Gang Enclosure.
4. Install the 2-Gang White Switch Plate on the Metal 2-Gang Enclosure.
5. Run and secure the Plenum Cable Encased in 16mm ENT Flexible Conduit to the Hood.
6. Use one of the Knock-Outs (KO) in the back of the Hood as an entry point.
7. Plug the Eight-Position male and female connectors together inside the Hood (labeled ADA Plug).
8. Ensure that the electrical connections are secured.
9. Turn the power ON for the Hood.
10. The switch on the left of the Metal 2-Gang Enclosure with the Red and White wires connected to it, is for the fan function. Turning ON this switch, enables the fan to run at High Speed only. There is no speed control with this switch.

NOTE: To turn the fan OFF, both the ADA toggle switch and the fan switch at the Hood need to be OFF.

11. The switch on the right of the Metal 2-Gang Enclosure with Black and White wires connected to it is for the light function.

NOTE: To turn the light OFF, both the ADA toggle switch and the light switch at the Hood need to be OFF.

HANDICAP ACCESSIBLE CONTROL (ADA)

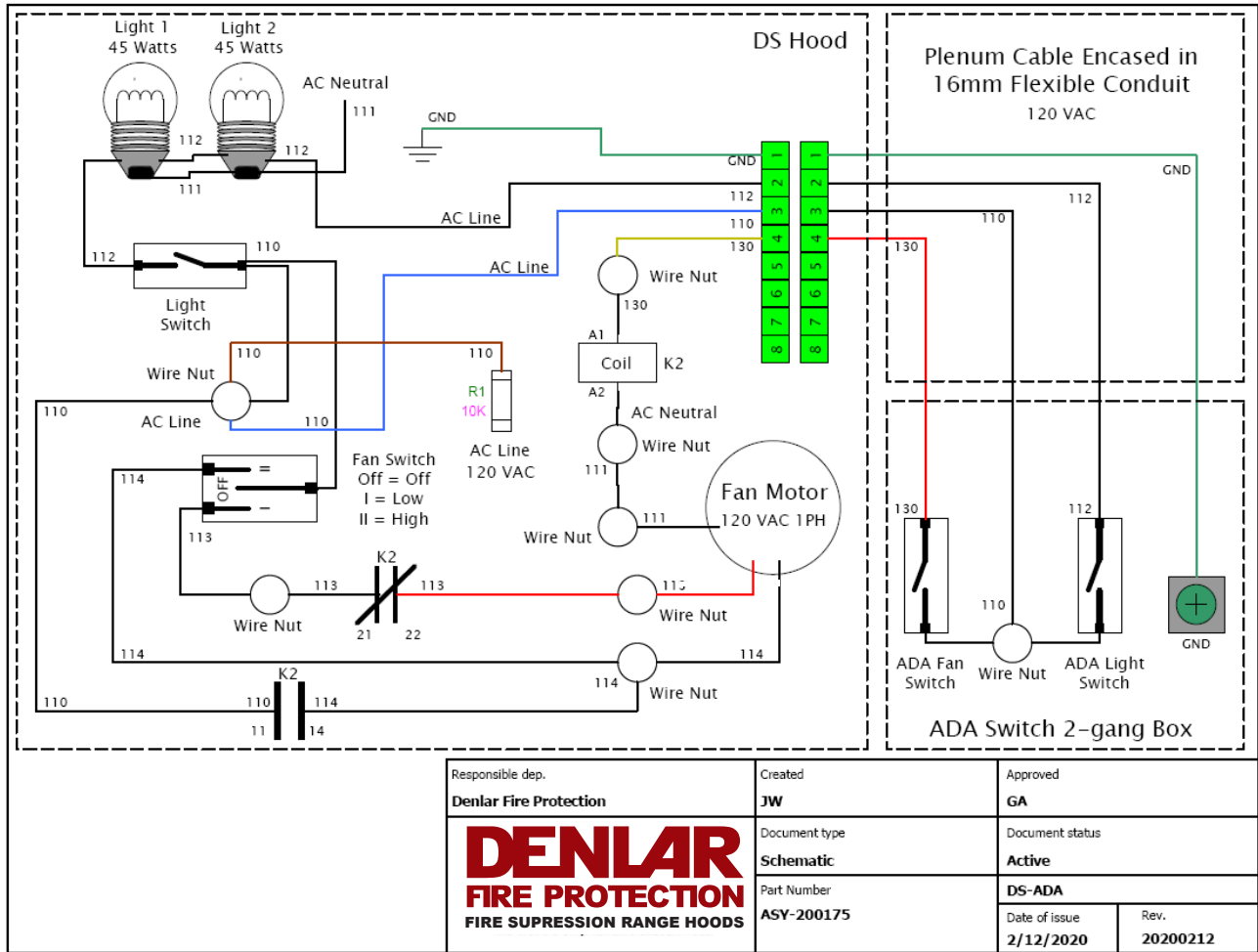

Responsible dep. Denlar Fire Protection	Created JW	Approved GA
DENLAR FIRE PROTECTION FIRE SUPPRESSION RANGE HOODS	Document type Schematic	Document status Active
	Part Number ASY-200175	DS-ADA
	Date of issue 2/12/2020	Rev. 20200212

TANK REMOVAL

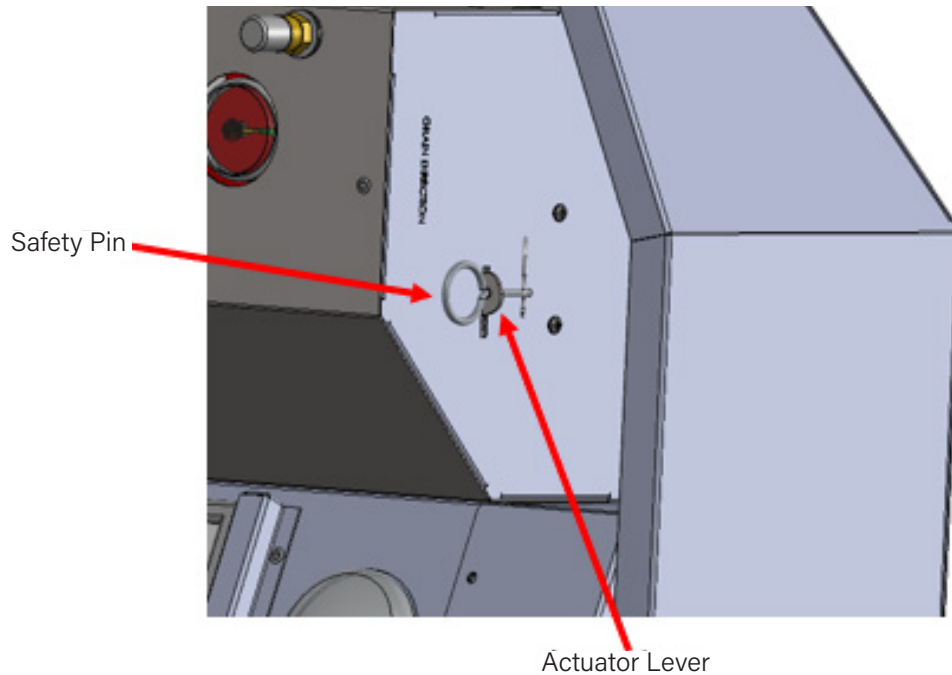

Safety Pin Installation

Prior to removing the Designer Series Tank Assembly, ensure that the Safety Pin is installed correctly into the Actuator Lever. It is recommended to tie-wrap the Safety Pin to the Actuator Lever as a secondary safety measure.

Remove Tank Assembly

To remove the Designer Series Tank Assembly, a $\frac{3}{8}$ " socket or Nut Driver is required. Start by removing the Side Cover from the Hood. Inside the housing there is a Six-Position connector with three red wires, two blue wires, and one black wire; unplug the Six-Position connector. The male end connects to the microswitches in the Designer Series Tank Assembly. If a Manual Pull Station is installed, remove the swivel hook from the glass link. Using a $\frac{3}{8}$ " socket or Nut Driver, remove the two Tank Securing Nuts. The Designer Series Tank Assembly can be removed safely at this time. To reinstall the Designer Series Tank Assembly, reverse this process.

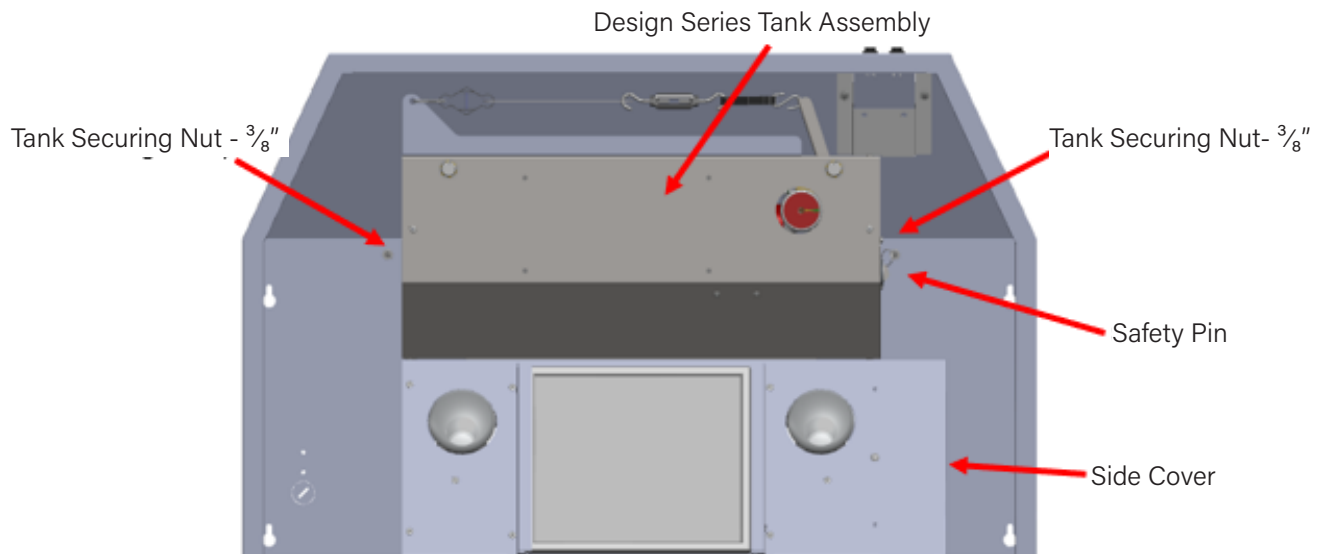

DESIGNER SERIES TESTING

Testing the Designer Series Hood Fan and Light

1. Turn the Light Switch ON and ensure both lights turn ON.
2. Turn the Light Switch OFF and ensure both lights turn OFF.
3. The Fan Switch is a Three-Position rocker switch. The positions are marked "O", "I", and "II". The "O" marking keeps the fan motor OFF. The "I" marking sets the fan motor to LOW speed. The "II" marking sets the fan motor to HIGH speed. If the Hood is equipped with an inline fan motor, then the fan switch is an ON or OFF switch, there is no two speed control. Test the different positions of the switch to ensure correct functionality.
4. Testing the 120 VAC Output Control Signal to the Power Disconnect and the Alarm Signal, requires the removal of the microswitch from the Tank Assembly.
 - a. To do this, ensure the Safety Pin is installed correctly into the Actuator Lever. It is recommended to tie wrap the Safety Pin to the Actuator Lever as a secondary safety measure.
 - b. Remove the Side Cover from the Hood. Inside this area, there is a Six-Position connector with three red wires, two blue wires, and one black wire.

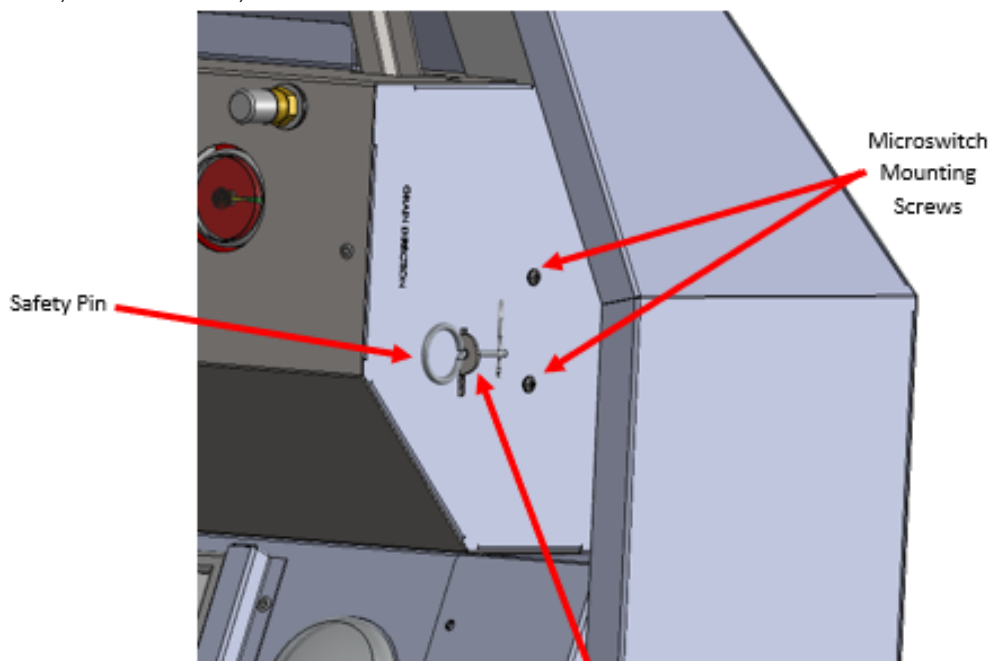
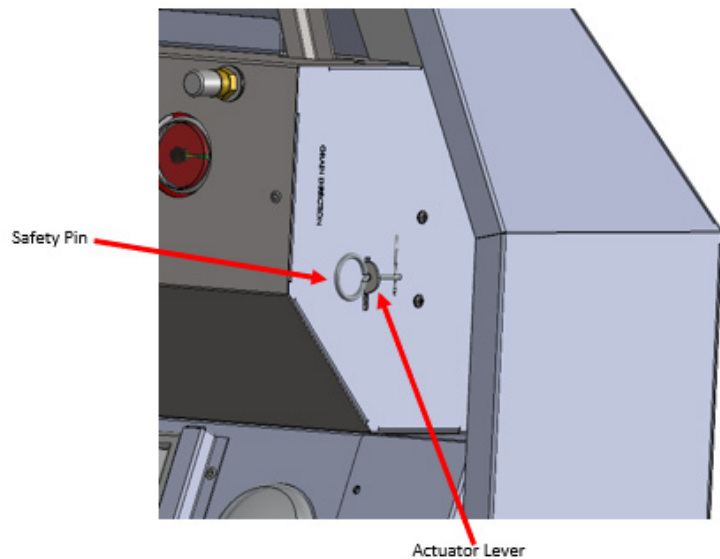
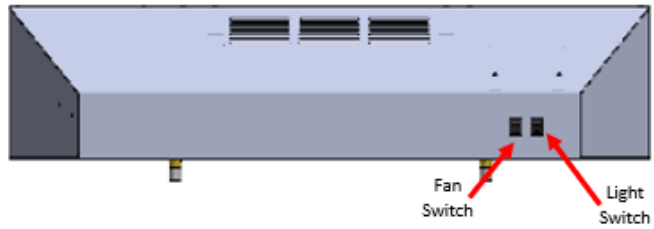

DESIGNER SERIES TESTING

Disconnect the Six-Position connector. The male end connects to the microswitches in the Designer Series Tank Assembly.

- a. If a Manual Pull Station is installed, remove the swivel hook from the glass link.
- b. Using a $\frac{3}{8}$ " socket or Nut Driver, remove the two Tank Securing Nuts. The Designer Series Tank Assembly can be removed safely at this time.
- c. There are two mounting screws securing the microswitches to the Tank Assembly Housing. Remove these screws.
- d. Plug the microswitch Six-Position connector into the same connector it was removed from. Pushing down on the microswitches levers, changes the state of the contacts.

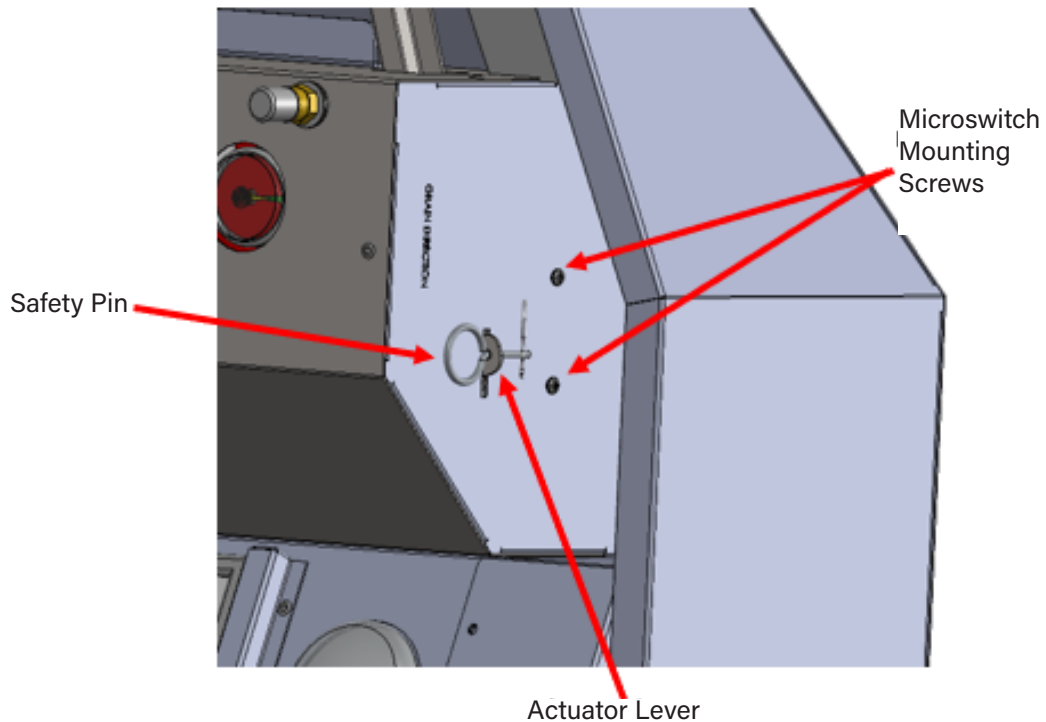

- i. The microswitch with the two blue wires and one black wire, controls the Power Disconnect and the Audible Buzzer. With the microswitch disengaged, the Audible Buzzer sounds. With the microswitch engaged, the Power Disconnect coil is powered.
 - ii. The microswitch with three red wires is connected to the building fire alarm. Engaging this contact will change its state.
- e. Once the test is completed, reinstall the two microswitches. Verify that the microswitches are engaged and pressing on the tank's actuator lever.
 - f. Reverse the steps to reinstall the tank assembly.

DESIGNER SERVICE

Before servicing the Designer Series Hood, install the Safety Pin for the tank to prevent an accidental discharge.

Inspection:

1. Verify that all components are clean, non-damaged, and have no corrosion. Corrosion could be a sign that there is an issue with the tank.
2. Verify that the Pressure Gauge is in the green section.
3. Verify the Fan Motor works.
4. Verify the Light Bulbs work.
5. Verify the Range powers ON.
6. Verify the Glass Links (2x) are clean and secured.
 - a. To replace the Glass Links, ensure that the Safety Pin is installed. Use the Turnbuckle to loosen tension on the Glass Links. Replace the Glass Links and retighten the Turnbuckle.
7. Inspect the Nozzles (2x) for grease or debris.
 - a. Remove the Nozzle Caps to inspect that the Nozzle Spray orifice is not clogged.
 - ii. If the Nozzle is clogged, it needs replacement. Do not try to clear a clogged Nozzle by inserting a pin or any other object. This may cause the obstruction to go deeper into the Nozzle.

RECOMMEND MAINTENANCE SCHEDULE			
	Monthly	Semi-Annually	Annually
Cleaning	Clean Grease Filter & Grease Tray, Wipe Hood, Links, and Wire Rope to Remove Grease Build Up.		
Discharge Nozzles	Inspect for Grease build- up, etc. Clean and/or replace as needed.		
Fusible Links	Inspect for signs of loosening and wear; if any is present replace as needed.	Replace on a semi-annual basis once the unit has gone into service or as required by local code(s).	
Extinguisher Tank	Inspect for signs of loosening and wear; if any is present replace as needed.		Recertify

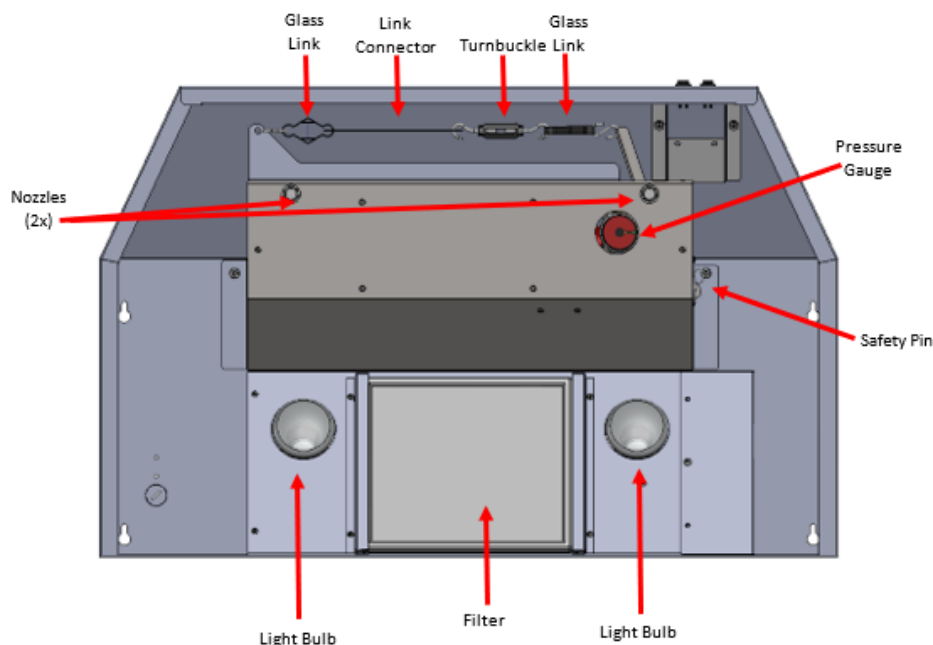

DESIGNER SERIES DEVICE FLOW CHART

DEVICE FLOW CHART

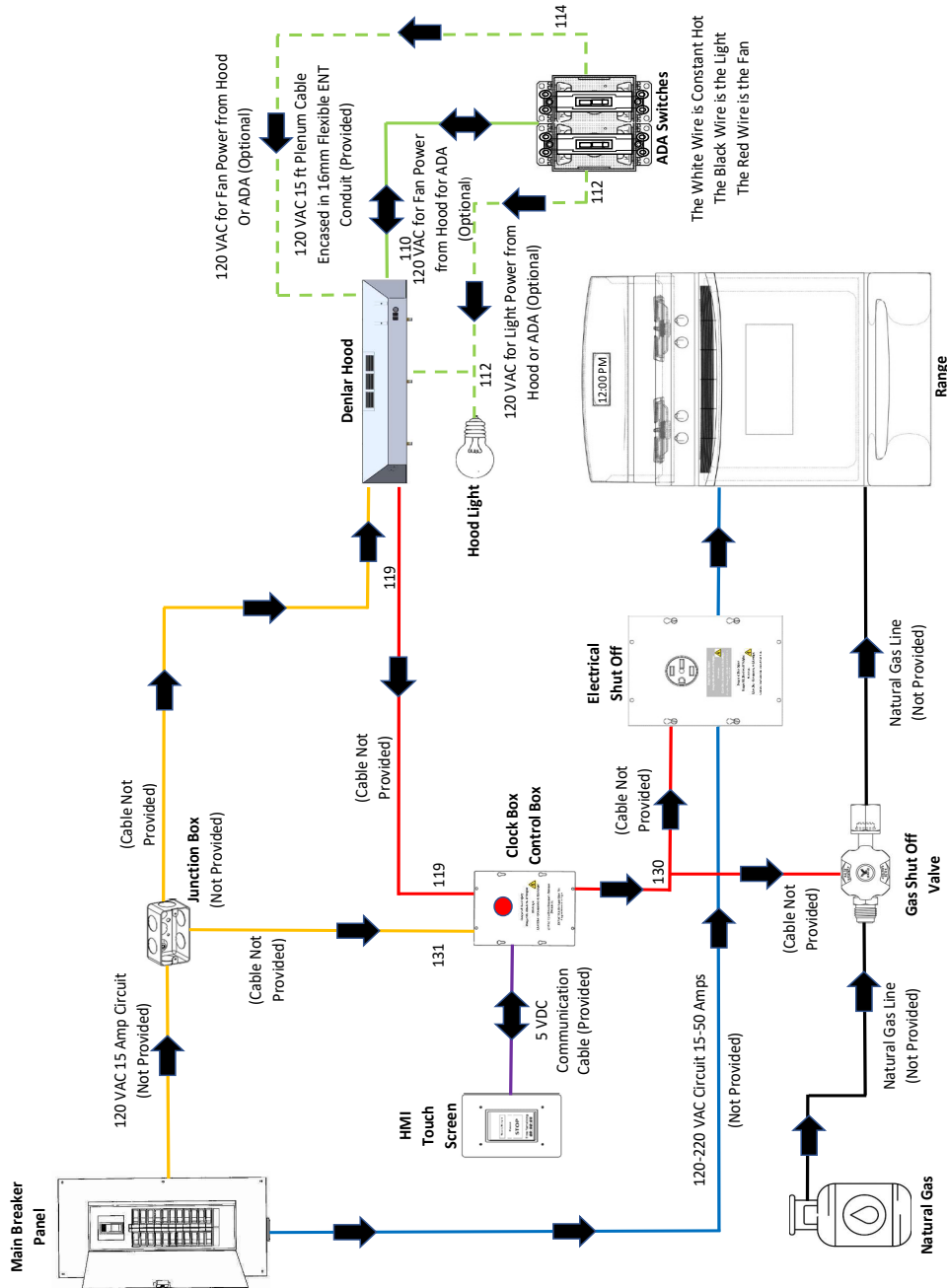

- Legend**
- The Orange Color Lines represents the Main 120 VAC Power from the Main Breaker Panel to the Hood and Clock Box (Optional).
 - The Blue Color Lines represent the Main 220 VAC 50 Amp Circuit for an Electric Range or the 120 VAC for a Gas Range Ignitors and miscellaneous Electrical Components.
 - The Black Lines represents the Natural Gas Line.
 - The Purple Lines represents the 5VDC Communication Cable for the Clock Box Control Box to the HMI Touch Screen.
 - The Red Lines represents the 120 VAC the Hood sends to the Electrical Shut Off, the Gas Shut Off Valve, or the Clock Box (Optional).
 - The Green Lines represents the ADA (Optional).
 - The Green Dotted Lines represent the signal sent from the ADA to the corresponding components. The physical wires are in the ADA harness, (see Legend #6).

DENLAR
FIRE PROTECTION
PRE-ENGINEERED RANGE HOODS
 The World's Only Fail-Safe UR360A Hood

THIS PAGE IS INTENTIONALLY BLANK

DENLAR™

FIRE PROTECTION

1700 Parker Drive | Charlotte NC 28208 USA |
704-372-3485 | sales@denlarhoods.com | www.denlarhoods.com



For the Warranty Statement please visit <https://www.denlarhoods.com/>

For installation or service calls please contact Denlar service at 704-372-3485 or at service@denlarhoods.com

For sales questions, please contact Denlar Sales at 704-372-3485 or at sales@denlarhoods.com

A Proud USA Manufacturer

Not responsible for typographical errors. Continuing research results in manufacturing improvements, therefore specifications are subject to change without notice. For the most updated information, please contact Denlar directly. DL1241B 6/25 LAB-110085